

SECTIONAL VIEW - INFINITY Model 3648 TYPE 3

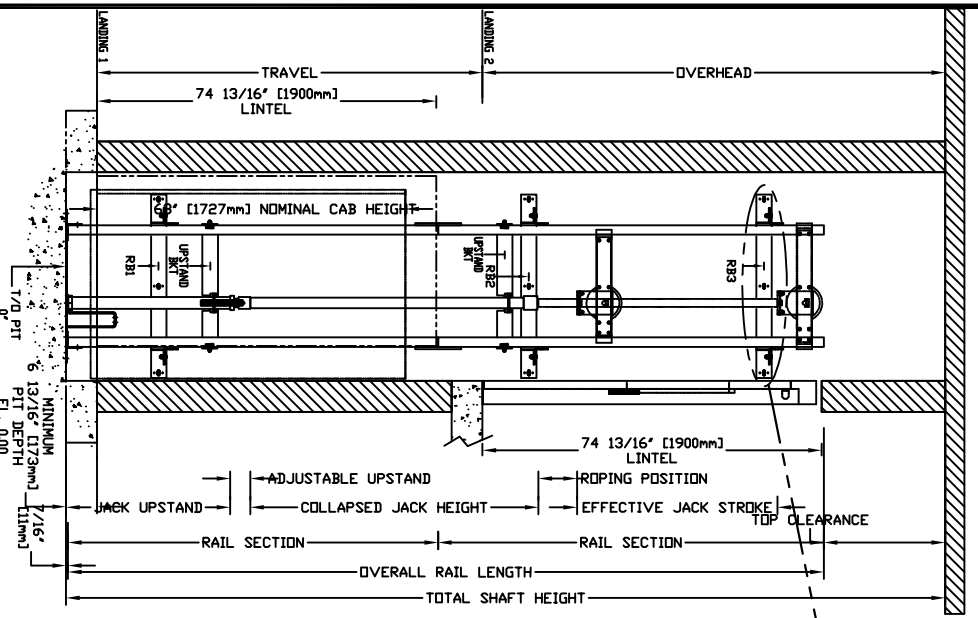

TOP RAIL BRACKET RB3	AT TOP OF CONSTANT CONCORD REPRESENTATIVE FOR EXACT LOCATION	FLOOR No.	FLOOR HEIGHT
INTERMEDIATE RAIL BRACKET RB2	96" (2438mm) INTERVALS ABOVE BOTTOM BRACKET	REAR FRONT	
BOTTOM RAIL BRACKET RB1	24" (610mm) ABOVE PIT FLOOR		TOTAL RISE

PIT / OVERHEAD REQUIREMENTS

MAX. SPEED (ft/min)	MIN. PIT	TOTAL TRAVEL	MINIMUM OVERHEAD
36	8' ***		92' (2837)

*** NOTE: Additional pit equipment required when over 36' [914.4mm] deep, consult your local dealer for details.

DOCUMENT REVISION 001. DATE: 04/24/07

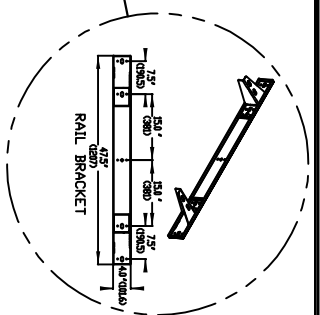

PLAN VIEW - INFINITY Model 3648 TYPE 3

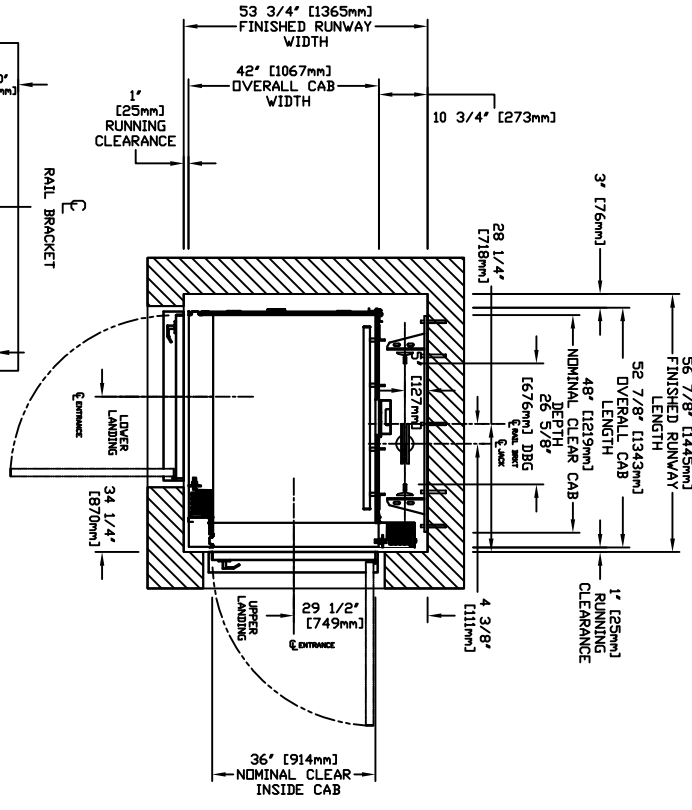

RAIL BRACKET

RAIL FORCES	R3 NOTE:
* R1	PIT FLOOR TO SUPPORT LOAD OF 5skips * (INCLUDES IMPACT)
* R2	PER TOTAL RAIL-TO-TOE FORCE ON RAIL BRACKET, IT MUST BE DOUBLED UP.
30k/ft	
194k/ft	
RAIL WEIGHT = 83 lbs / ft	

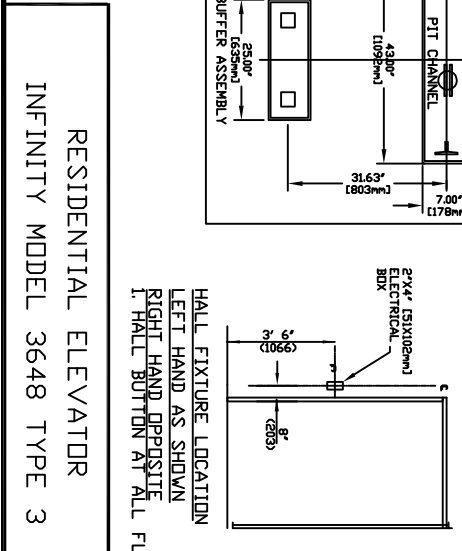

RESIDENTIAL ELEVATOR INFINITY MODEL 3648 TYPE 3

PROVISIONS BY OTHERS

***GENERAL**
 HOISTWAY - THE HOISTWAY MUST BE IN ACCORDANCE WITH "SAFETY CODE FOR ELEVATORS" (944 SECTION 5.2), "SAFETY CODE FOR ELEVATORS AND ESCALATORS" (ASME A17.1) AND ALL STATE/PROVINCIAL AND LOCAL CODES.
 PLUMB HOISTWAY - DUE TO CLOSE RUNNING CLEARANCES OWNER/AGENT MUST ENSURE THAT HOISTWAY AND PIT (WHERE PROVIDED) ARE LEVEL, PLUMB AND SQUARE AND ARE IN ACCORDANCE WITH THE DIMENSIONS ON THESE DRAWINGS.
 MINIMUM OVERHEAD CLEARANCE - OWNER/AGENT MUST ENSURE MINIMUM OVERHEAD CLEARANCE IS IN COMPLIANCE WITH CODES.
 CONSTRUCTION SITE - OWNER/AGENT TO PROVIDE ALL MASONRY, CARPENTRY AND DRYWALL WORK AS REQUIRED AND SHALL PATCH AND MAKE GOOD (INCLUDING FINISH PAINTING) ALL AREAS WHERE WALLS/FLOORS MAY REQUIRE TO BE CUT, DRILLED OR ALTERED IN ANY WAY TO PERMIT THE PROPER INSTALLATION OF THE LIFT.
 DIMENSIONS - CONTRACTOR/CUSTOMER TO VERIFY ALL DIMENSIONS AND REPORT ANY DISCREPANCIES TO OUR OFFICE IMMEDIATELY.
***STRUCTURAL**
 ELEVATOR/SUPPORT WALL LOADS - STRUCTURAL ENGINEER TO ASSURE THAT BUILDING AND SHAFT WALL SAFELY SUPPORT ALL LOADS IMPOSED BY THE LIFT EQUIPMENT REFER TO THE TABLES ON THIS DRAWING FOR LOADS IMPOSED BY THE EQUIPMENT.
 WHERE DOORS ARE REQUIRED - SUITABLE LINTELS MUST BE PROVIDED BY OWNER/AGENT. DOOR FRAMES ARE NOT DESIGNED TO SUPPORT DIVERSED WALL LOADS.
***MACHINE ROOM**
 LOCATION / ACCESS - MACHINE ROOM LOCATED AT THE LOWEST LEVEL ADJACENT TO HOISTWAY, UNLESS SHOWN OTHERWISE ON THE LAYOUT DRAWINGS. FIELD ADJUSTMENT BY INSTALLER MAY BE NECESSARY TO MEET JOB SITE CONDITIONS OR REGULATIONS. ACCESS TO MACHINE ROOM TO BE THROUGH A SELF CLOSING LOCKING DOOR. SLEEVES FOR OIL & ELECTRIC LINES - FROM MACHINE ROOM TO RUNWAY AS REQUIRED. POSITION PER INSTALLER'S INSTRUCTIONS.

MOTOR INFO	INPUT VOLTAGE (V/PH/CTD)	DISCONNECT SIZE (AMPS)	TIME DELAY (SECS)	FULL LOAD FUSE (AMPS)	CURRENT (AMPS)
	30	30	20	10.6	
	60	60	30	17.0	
	115/1PH		15		

***ELECTRICAL**
 OWNER SUPPLY - (SEE SPECIFICATIONS) LOCKABLE FUSED DISCONNECT WITH AUXILIARY CONTACT TO BREAK THE BATTERY FEED, OR CIRCUIT BREAKERS WITH A 3-POLE BREAKER FOR BATTERY FEED REQUIRED, IN COMPLIANCE WITH ELECTRICAL CODE, AS FOLLOWS:
 (LOCATED ON WALL ON LOCK JAMB SIDE OF MACHINE ROOM DOOR) PERMANENT POWER - BEFORE INSTALLATION CAN BEGIN, PERMANENT POWER MUST BE SUPPLIED.
 LIGHTING - OWNER/AGENT TO ENSURE AT LEAST 5 FTC OR 54 LUX AMBIENT LIGHTING OVER LIFT AREA.
***ENTRANCES**
 FASCIA PANEL - BELOW UPPER LEVEL ENTRANCE - WHERE REQUIRED, FASCIA PANEL MUST BE FASTENED TO A SOLID WALL AND BE PERPENDICULAR TO THE FLOOR AND WALLS. HOISTWAY FASCIA IS NOT SELF-SUPPORTING FOR LOADS. CONTINUOUS RUNS VOID OF ENTRANCES. ADEQUATE SUPPORT FOR THE FASCIA MUST BE PROVIDED.
 ENTRANCE ASSEMBLIES - ENTRANCE ASSEMBLIES MUST BE ADJUSTED TO ALIGN WITH PLATFORM AND INTERLOCK EQUIPMENT. OTHERS TO ALLOW AN ADEQUATE ROUGH OPENING.
 RETURN WALLS - RETURN WALLS AT ENTRANCES MUST BE BUILT-IN BY OTHERS AFTER ENTRANCE ASSEMBLIES ARE IN PLACE. ENTRANCE ASSEMBLY MUST BE SECURELY FASTENED TO WALLS BY ELEVATOR CONTRACTOR.

NOTE 1
 ALL INFORMATION IS SUBJECT TO CHANGE. PLEASE REFERENCE OUR ON-LINE DRAWINGS AT WWW.CONCORDRELEVATOR.COM FOR THE MOST RECENT UPDATES

NOTE 2
 THE INFORMATION DISCLOSED HEREIN IS THE EXCLUSIVE PROPERTY OF savaria. AND MAY NOT BE USED BY OTHERS WITHOUT WRITTEN CONSENT

CUSTOMER: _____
 PROJECT: _____
 LOCATION: _____
 DATE: _____
 REVISION DATE: _____
 COMPLETED BY: _____

SAVARIA