

SECTIONAL VIEW - INFINITY Model 4054 TYPE 1R

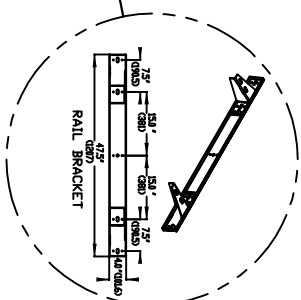

RAIL FORCES		R3 NOTE:	
* R1	* R2	PIT FLOOR TO SUPPORT LOAD OF 5600lbs * (INCLUDES IMPACT)	
FOR TOTAL PULL-OUT FORCE ON RAIL BRACKET, R1 MUST BE DOUBLED * 9			
RAIL WEIGHT: 60 lbs / 7 ft			

PLAN VIEW - INFINITY Model 4054 TYPE 1R

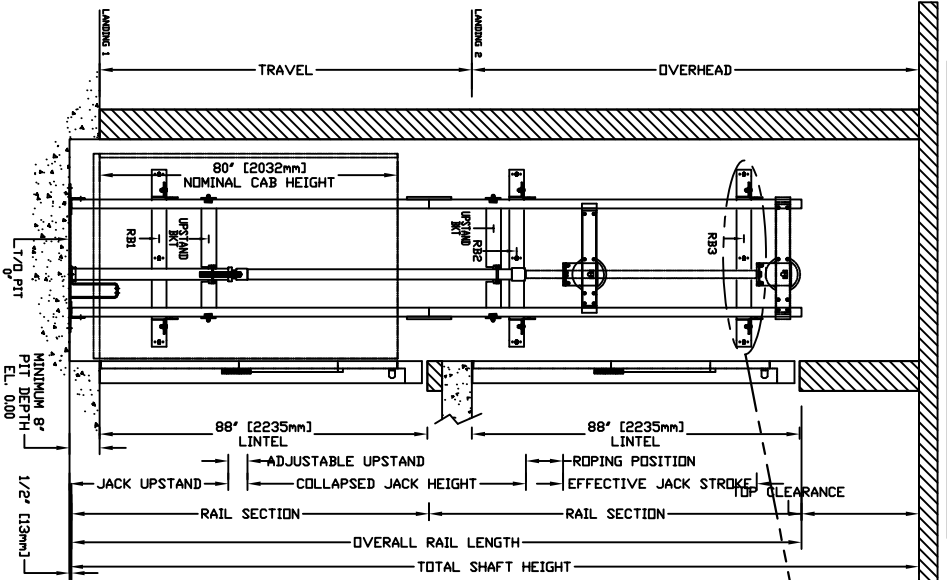
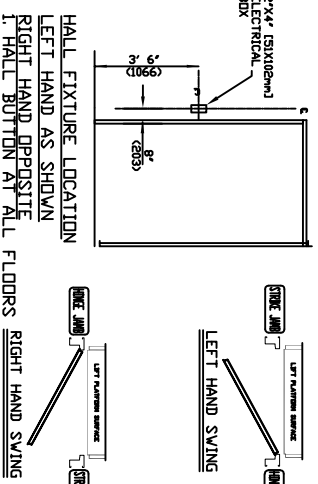
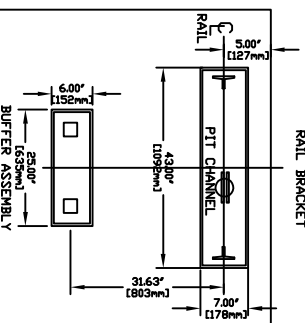
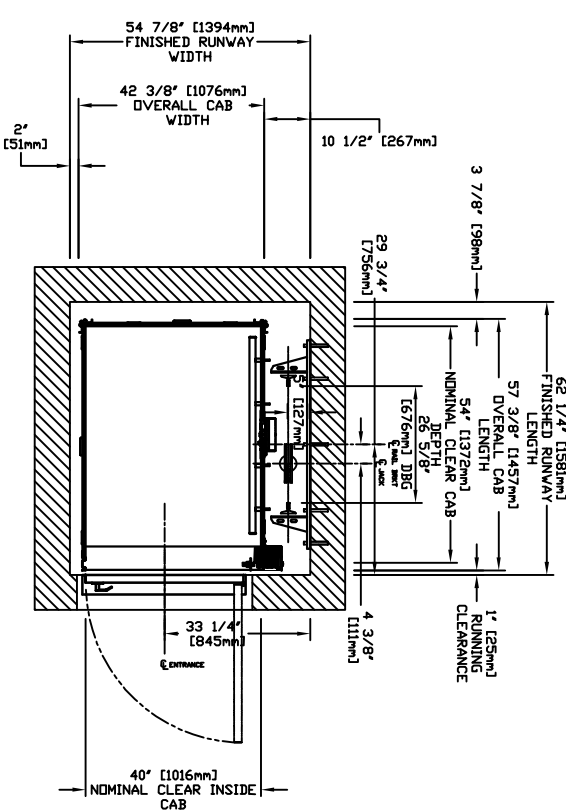

PIT / OVERHEAD REQUIREMENTS			
MAX. SPEED (ft./min)	MIN. PIT	TOTAL TRAVEL	MINIMUM OVERHEAD
36	8' ***	92' (2337)	92' (2337)

*** NOTE: Additional pit equipment required when over 36" [914.4mm] deep, consult your local dealer for details.

DOCUMENT REVISION 003, DATE: 04/24/07

PROVISIONS BY OTHERS

***GENERAL**
HOISTWAY - THE HOISTWAY MUST BE IN ACCORDANCE WITH SAFETY CODE FOR ELEVATORS, 944 SECTION 5.2, SAFETY CODE FOR ELEVATORS AND ESCALATORS, (ASME A17.1) AND ALL STATE/PROVINCIAL AND LOCAL CODES.

PLUMB HOISTWAY - DUE TO CLOSE RUNNING CLEARANCES OWNER/AGENT MUST ENSURE THAT HOISTWAY AND PIT (WHERE PROVIDED) ARE LEVEL, PLUMB AND SQUARE AND ARE IN ACCORDANCE WITH THE DIMENSIONS ON THESE DRAWINGS.

MINIMUM OVERHEAD CLEARANCE - OWNER/AGENT MUST ENSURE MINIMUM OVERHEAD CLEARANCE IS IN COMPLIANCE WITH CODES.

CONSTRUCTION SITE - OWNER/AGENT TO PROVIDE ALL MASONRY, CARPENTRY AND DRYWALL WORK AS REQUIRED AND SHALL PATCH AND MAKE GOOD (INCLUDING FINISH PAINTING) ALL AREAS WHERE WALLS/FLOORS MAY REQUIRE TO BE CUT, DRILLED OR ALTERED IN ANY WAY TO PERMIT THE PROPER INSTALLATION OF THE LIFT.

***DIMENSIONS**
CONTRACTOR/CUSTOMER TO VERIFY ALL DIMENSIONS AND REPORT ANY DISCREPANCIES TO OUR OFFICE IMMEDIATELY.

***STRUCTURAL**
FLOOR/SUPPORT WALL LOADS - STRUCTURAL ENGINEER TO ASSURE THAT BUILDING AND SHAFT WILL SAFELY SUPPORT ALL LOADS IMPOSED BY THE LIFT EQUIPMENT. REFER TO THE TABLES ON THIS DRAWING FOR LOADS IMPOSED BY THE EQUIPMENT.

WHERE DOORS ARE REQUIRED - SUITABLE LINTELS MUST BE PROVIDED BY OWNER/AGENT. DOOR FRAMES ARE NOT DESIGNED TO SUPPORT OVERHEAD WALL LOADS.

***MACHINE ROOM**
LOCATION / ACCESS - MACHINE ROOM LOCATED AT THE LOWEST LEVEL ADJACENT TO HOISTWAY, UNLESS SHOWN OTHERWISE ON THE LAYOUT DRAWINGS. FIELD ADJUSTMENT BY INSTALLER MAY BE NECESSARY TO MEET JOB SITE CONDITIONS OR REGULATIONS. ACCESS TO MACHINE ROOM TO BE THROUGH A SELF CLOSING LOCKING DOOR.

SLEEVES FOR OIL & ELECTRIC LINES - FROM MACHINE ROOM TO RUNWAY AS REQUIRED. (POSITION PER INSTALLERS INSTRUCTIONS).

INPUT VOLTAGE	DISCONNECT	TIME DELAY	FULL LOAD
(V/PH/PHASE) <td>SIZE (AMPS) <td>FUSE (AMPS) <td>CURRENT (AMPS) </td></td></td>	SIZE (AMPS) <td>FUSE (AMPS) <td>CURRENT (AMPS) </td></td>	FUSE (AMPS) <td>CURRENT (AMPS) </td>	CURRENT (AMPS)
MOTOR INFO	30	20	10.6
CAB LIGHTS	115/1PH	60	30
		15	17.0

***ELECTRICAL**
OWNER SUPPLIES (SEE SPECIFICATIONS) LOCKABLE FUSED DISCONNECT WITH FULCRUM CONTACT BREAKER, THE BATTERY FEED, OR CIRCUIT BREAKERS WITH 50 AMP BREAKER FOR AS FULCRUM FEED IS REQUIRED. IN COMPLIANCE WITH ELECTRICAL CODES AS APPLICABLE. (LOCATED ON WALL ON LOCK LAMP SIDE OF MACHINE ROOM DOOR) PERMANENT POWER, BEFORE INSTALLATION CAN BEGIN, PERMANENT POWER MUST BE SUPPLIED.

LIGHTING - OWNER/AGENT TO ENSURE AT LEAST 5 FT-C OR 54 LUX AMBIENT LIGHTING OVER LIFT AREA.

***ENTRANCES**
FASCIA PANEL RELAY UPPER LEVEL ENTRANCE - WHERE REQUIRED, FASCIA PANEL MUST BE FASTENED TO SOLID WALL AND BE PERPENDICULAR TO THE FLOOR AND WALLS. HOISTWAY FASCIA IS NOT SELF-SUPPORTING FOR LONG CONTINUOUS RUNS. VOID OF ENTRANCES ADEQUATE SUPPORT FOR THE ENTRANCE ASSEMBLY. ENTRANCE ASSEMBLY MUST BE ADJUSTED TO ALIGN WITH PLATFORM AND INTERLOCK EQUIPMENT. OTHERS TO ALLOW AN ADEQUATE ROUGH OPENING.

RETURN WALLS - RETURN WALLS AT ENTRANCES MUST BE BUILT-IN BY OTHERS AFTER ENTRANCE ASSEMBLY IS IN PLACE. ENTRANCE ASSEMBLY MUST BE SECURELY FASTENED TO WALLS BY ELEVATOR CONTRACTOR.

NOTE 3
ALL INFORMATION IS SUBJECT TO CHANGE. PLEASE REFERENCE OUR ON-LINE DRAWINGS AT WWW.CONCORDELEVATOR.COM FOR THE MOST RECENT UPDATES

RESIDENTIAL ELEVATOR INFINITY MODEL 4054 TYPE 1R

CUSTOMER: _____ PROJECT: _____ LOCATION: _____ DATE: _____ REVISION DATE: _____ COMPLETED BY: _____

THE INFORMATION PROVIDED HEREIN IS THE EXCLUSIVE PROPERTY OF **savaria** INC. AND WILL BE USED BY OTHERS WITHOUT WRITTEN CONSENT.

SAVARIA SHERIDAN