

SECTIONAL VIEW - INFINITY Model 3654 TYPE 4

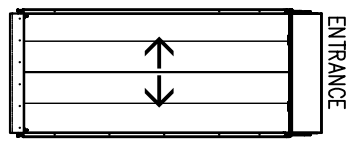

RAIL FORCES		R3 NOTE:	
* R1	* R2	PIT FLOOR TO SUPPORT LOAD OF 5.8kips	
30kHr.	194kHr.	* (INCLUDES IMPACT)	
RAIL WEIGHT - 8.0 lbs / ft		FOR TOTAL PULL-OUT FORCE ON RAIL BRACKET, R1 MUST BE DOUBLED *	

RAIL BRACKET

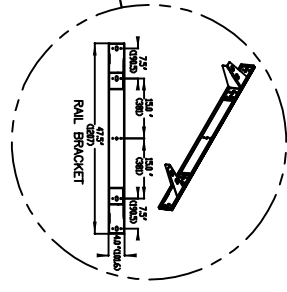
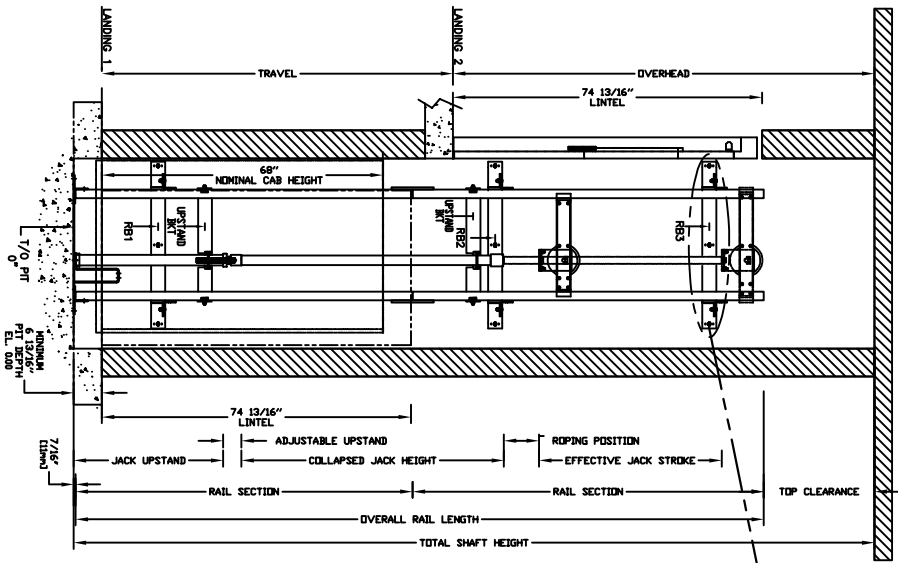
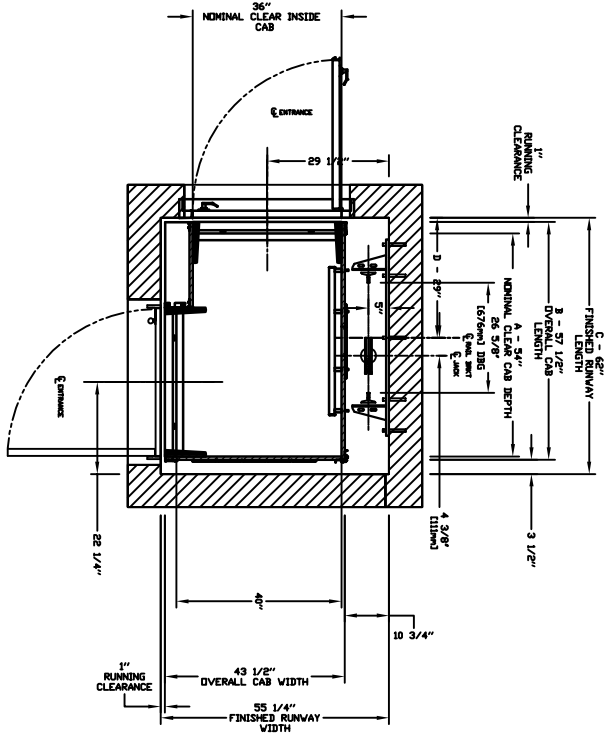

AT TOP OF HOISTWAY CONSULT YOUR RESPONSIBLE CONTRACTOR FOR EXACT LOCATION	FLOOR No. REAR FRONT	FLOOR HEIGHT
TOP RAIL BRACKET RB3		
INTERMEDIATE IN BEVELS BOTTOM BRACKET RB2		
BOTTOM RAIL BRACKET RB1		
TOTAL RISE		

PIT / OVERHEAD REQUIREMENTS			
MAX. SPEED (ft/min)	MIN. PIT	TOTAL TRAVEL	MINIMUM OVERHEAD
36	8" ***	92"(2337)	

*** NOTE: Additional pit equipment required when over 36" [914.4mm] deep. consult your local dealer for details

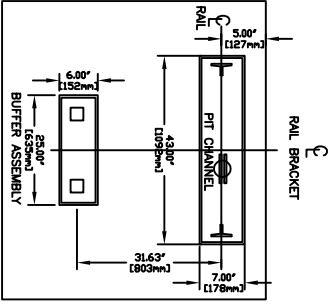

NOMINAL CLEAR INSIDE CAB LENGTH	A		B		C		D	
	mm	Inches	mm	Inches	mm	Inches	mm	Inches
1319	48	1308	51 1/2	1422	56	850	26	
1372	54	1481	57 1/2	1575	62	737	29	
1524	60	1613	63 1/2	1727	68	854	34	

RESIDENTIAL ELEVATOR INFINITY MODEL 3654 TYPE 4

CUSTOMER:	DATE:
PROJECT:	REVISION DATE:
LOCATION:	COMPLETED BY:

THE INFORMATION INDICATED HEREIN IS THE EXCLUSIVE PROPERTY OF savaria. AND MAY NOT BE USED BY OTHERS WITHOUT WRITTEN CONSENT.

