

INFINITY AUTO SLIM DOORS W Swing Door Model TYPE 1R

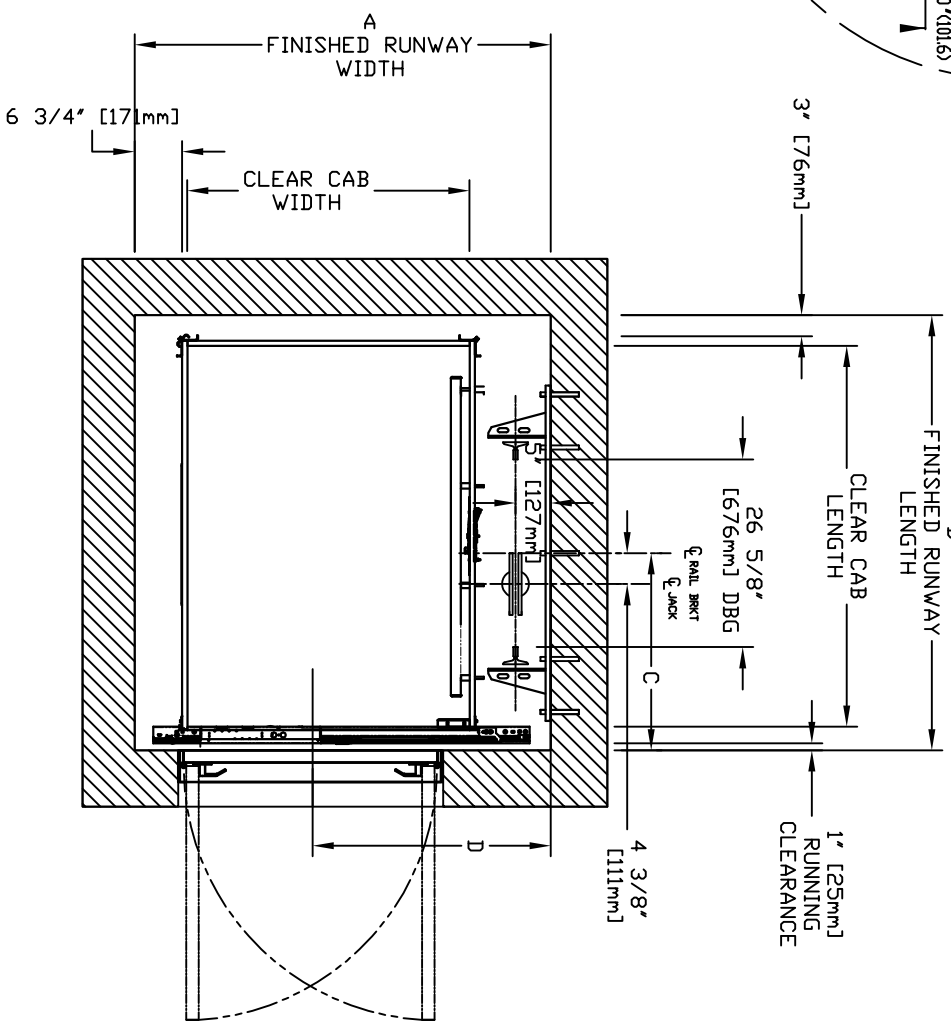
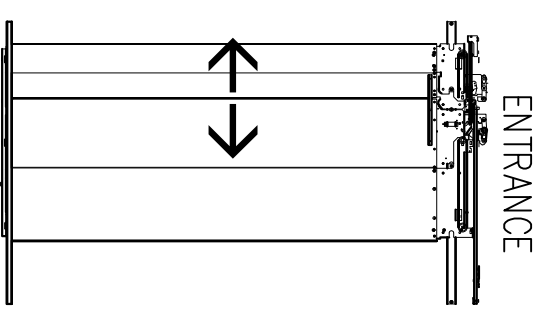
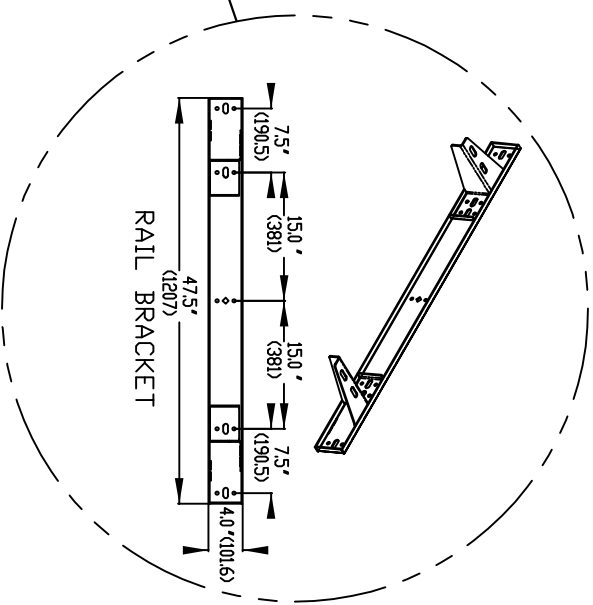
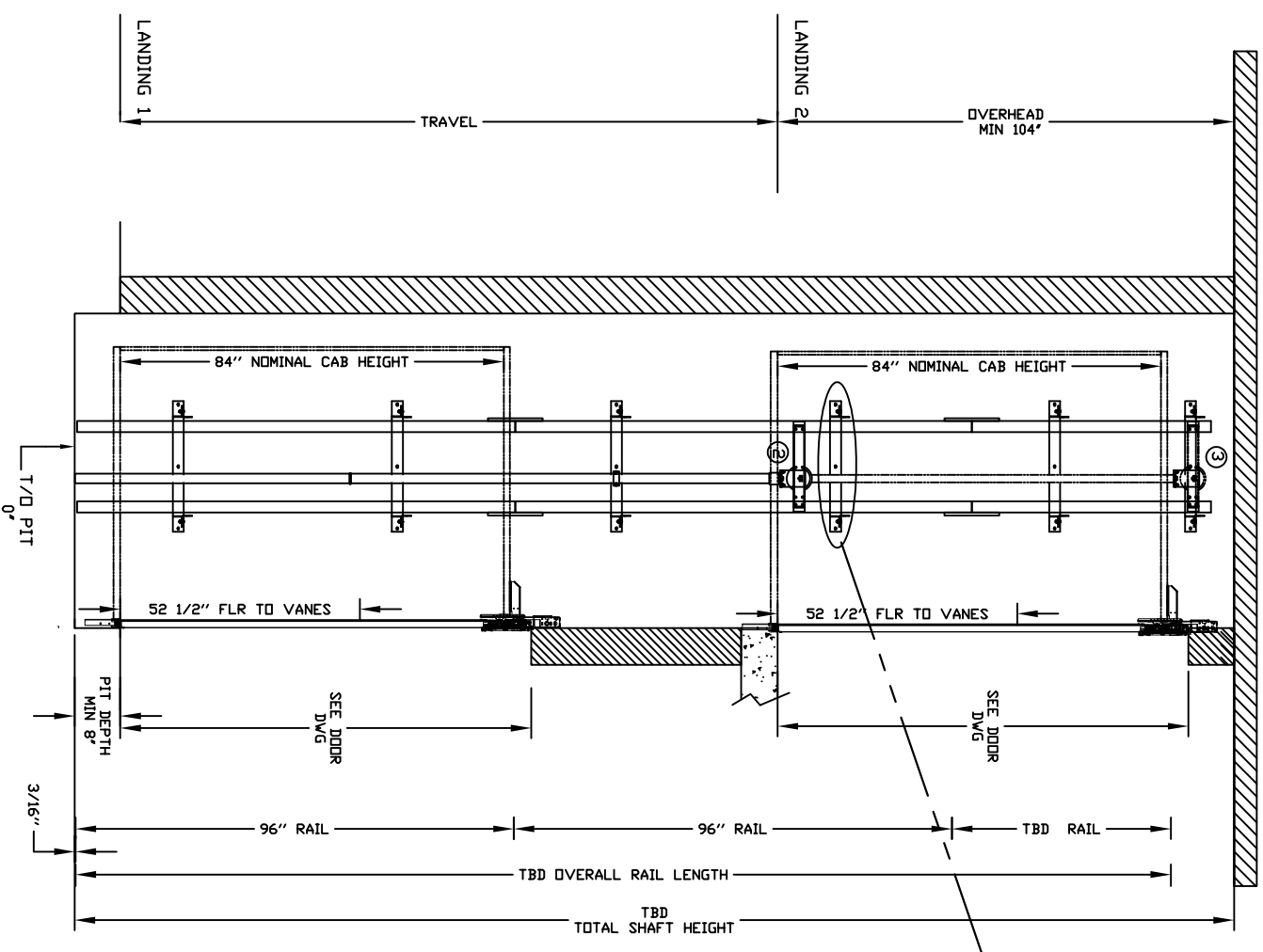

- ### CHARACTERISTICS
- CAB DOOR TYPE: AUTO SLIM 2 SPEED DOORS
 - ENTRANCE DOOR TYPE: AUTO SLIM 2 SPEED DOORS
 - 2 SPEED DOORS FINISH: PAINT OR STAINLESS STEEL
 - FULLY AUTOMATIC OPERATION TO OPEN THE DOORS UPON ARRIVAL AT THE LANDING
 - LIGHTWEIGHT ALUMINUM SILL
 - EMERGENCY BACK-UP BATTERY SYSTEM
 - INFRARED DETECTION SYSTEM TO RETRACT DOORS BEFORE HITTING AN OBSTRUCTION

mm	Inches	CLEAR INSIDE CAB WIDTH	CLEAR INSIDE CAB LENGTH	A		B		C		D	
				FINISHED RUNWAY WIDTH	FINISHED RUNWAY LENGTH	FINISHED RUNWAY WIDTH	FINISHED RUNWAY LENGTH	RAIL CENTER LINE	DOOR CENTER LINE		
914	36	1219	48	1499	59	1397	55	692	27 1/4	838	33
914	36	1372	54	1499	59	1549	61	768	30 1/4	838	33
914	36	1524	60	1499	59	1702	67	845	33 1/4	838	33
1016	40	1372	54	1524	60	1549	61	768	30 1/4	864	34
1219	48	1524	60	1626	64	1702	67	845	33 1/4	864	34

DOCUMENT REVISION 002, DATE: 09/04/18

RESIDENTIAL ELEVATOR

INFINITY SLIMS DOORS W Swing Door TYPE 1R

ENTRANCE SIDE LEGEND

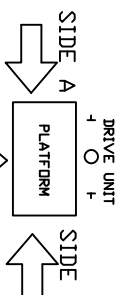

RAIL FORCES

*R1	*R2
304lbf.	194lbf.
RAIL WEIGHT : 80 lbs / ft	

R3 NOTE:
PIT FLOOR TO SUPPORT LOAD OF:
5.6kips * (INCLUDES IMPACT)
FOR TOTAL PULL-OUT FORCE ON RAIL BRACKET,
R1 MUST BE DOUBLED eg.

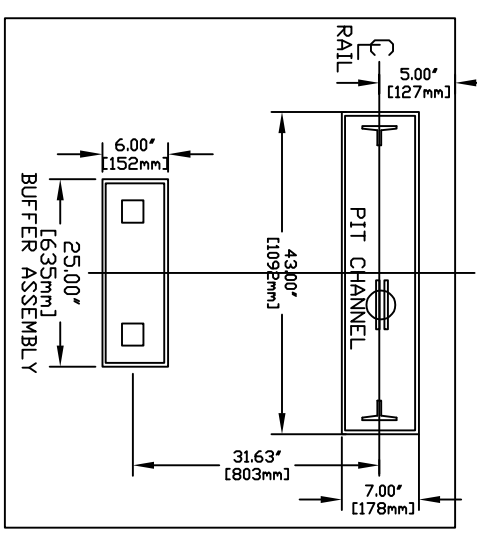

RAIL BRACKET

ALL INFORMATION IS SUBJECT TO CHANGE.
PLEASE REFERENCE OUR ON-LINE DRAWINGS AT
WWW.SAVARIA.COM FOR THE MOST RECENT UPDATES

