

GENERAL

CLASSIFICATION: STAIR LIFT
 MODEL: K2 PLUS
 CAPACITY: 158 kg [350 Lb]
 SPEED: 0.07 m/sec [13.78"/min]
 POWER SUPPLY: 110V, 15A, 60Hz, SINGLE PHASE
 MOTOR: 1/3 HP-24 VDC / 110V AC CHARGER
 DRIVE SYSTEM: RACK AND PINION
 APPLIED CODE: RESIDENTIAL OR COMMERCIAL

CONTROLLER

MODEL: LUT125 (OR PC125 WHERE APPLICABLE)
 TYPE: CPFS
 ETL#: 102116526MTL-001
 CONTROL VOLTS: 24VDC
 MFR.: LUTRON

SPECIFICATIONS

ANGLE OF STAIRCASE: 25° TO 55°
 LENGTH OF STAIRWAY: MAX 265"
 LOCATION: INDOOR
 SEAT COVERING COLOR: VINYL WHITE
 CALL STATION: REMOTE FOR RESIDENTIAL OR COMMERCIAL
 SAFETY FEATURE: OVERSPEED GOVERNOR

ANCHORING

WOODEN THREAD:
 ANCHOR EACH BRACKET SET USING A MINIMUM OF 4X Ø1/4 X 2" WOOD SCREW
 REINFORCED CONCRETE
 ANCHOR EACH BRACKET SET USING A MINIMUM OF 4X SLEEVE ANCHORS 1/4-2"
 METAL PLATE / BLOCK
 ANCHOR EACH BRACKET SET USING A MINIMUM OF 4X TRHU BOLT 1/4"
 BRACKET POSITION:
 WITHIN 18 INCHES [457] OF EACH END OF EACH SECTION OF TRACK
 IN THE CENTER OF EVERY SECTION OF TRACK LONGER THAN 4 FEET

OPTIONS

SIDE OF INSTALLATION: LEFT RIGHT
 QTY OF RAIL SECTION: _____ (94 1/2" EACH)
 FLIP-UP RAIL: YES
 BRACKET EXTENSION: YES
 EMERGENCY STOP SEAT: YES

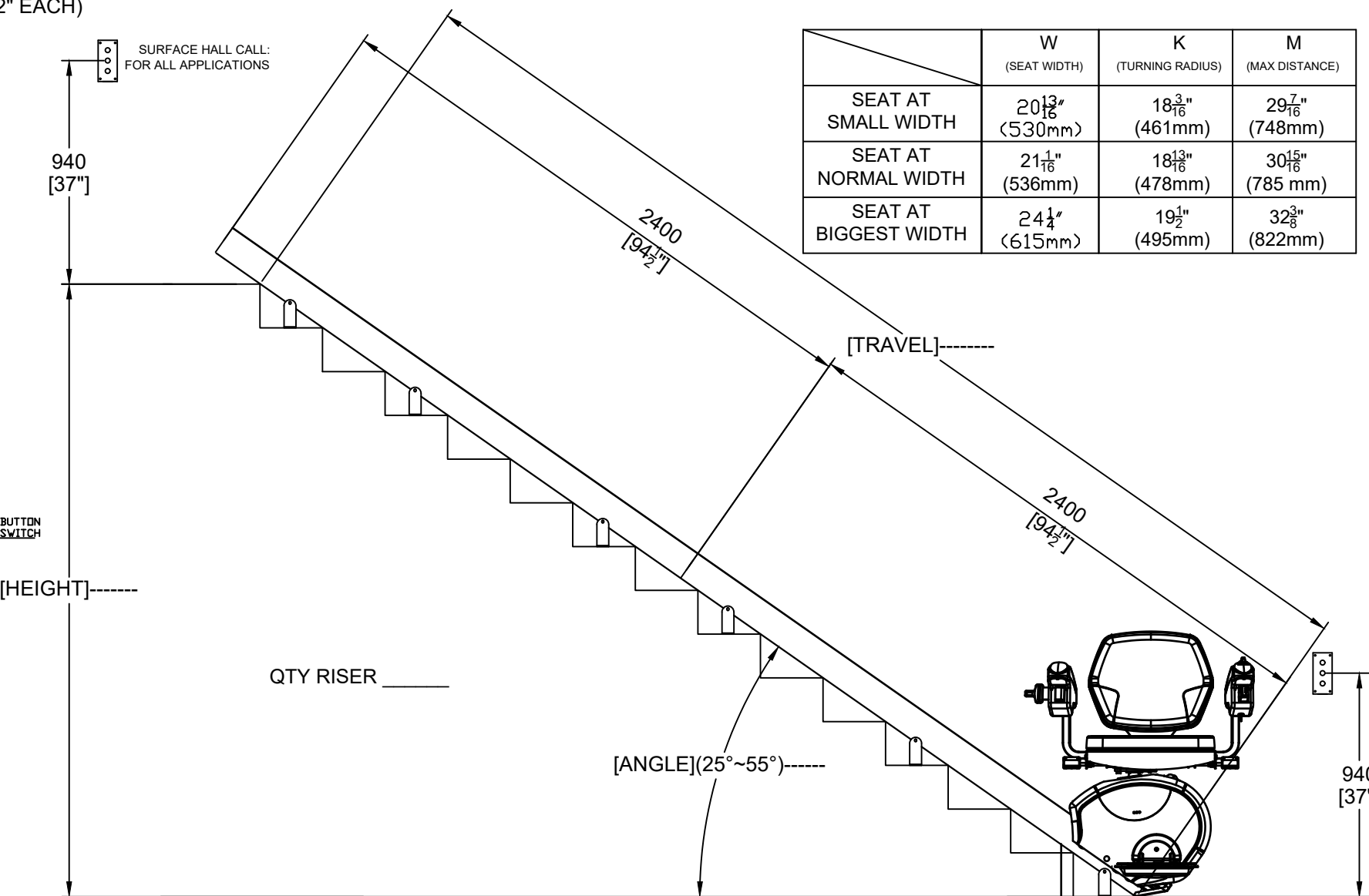
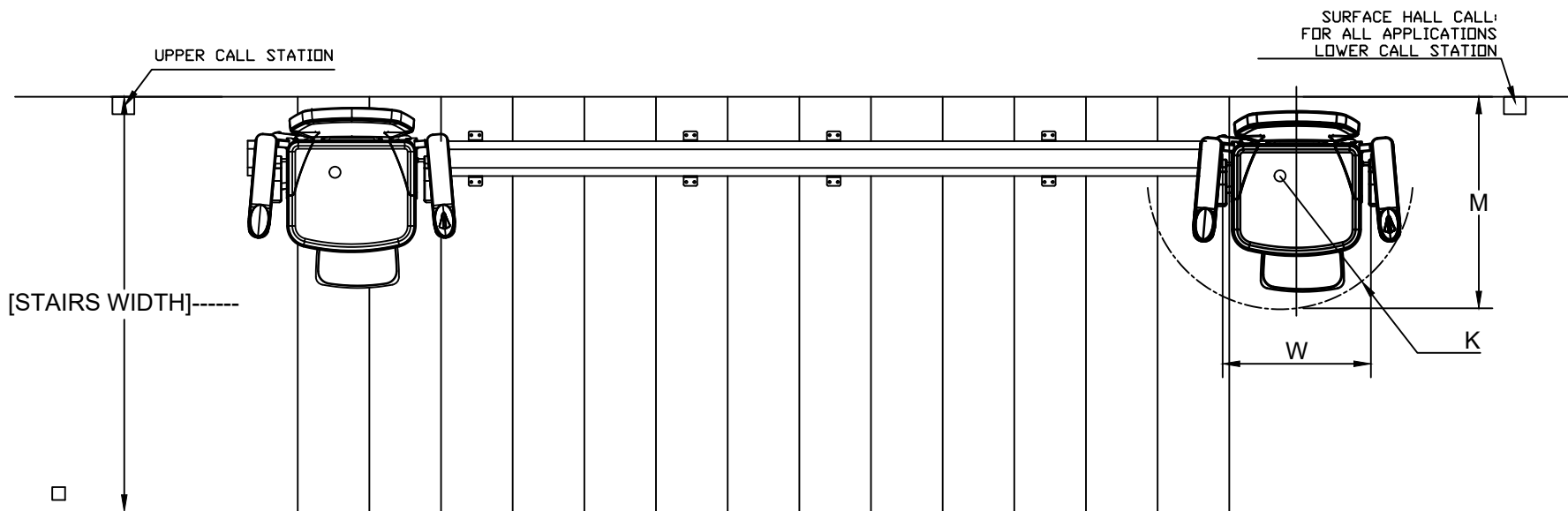

	W (SEAT WIDTH)	K (TURNING RADIUS)	M (MAX DISTANCE)
SEAT AT SMALL WIDTH	20 13/16" (530mm)	18 3/16" (461mm)	29 7/16" (748mm)
SEAT AT NORMAL WIDTH	21 1/16" (536mm)	18 13/16" (478mm)	30 15/16" (785 mm)
SEAT AT BIGGEST WIDTH	24 1/4" (615mm)	19 1/2" (495mm)	32 3/8" (822mm)

SUPPORT LOAD DIAGRAM

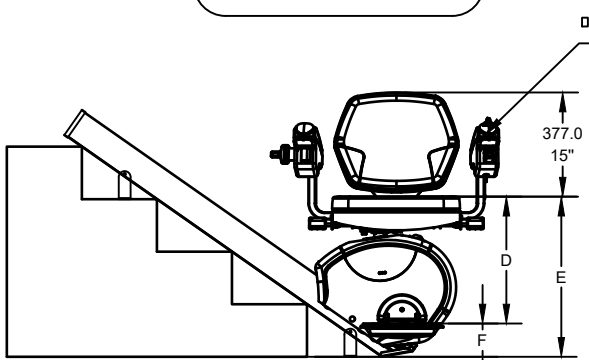
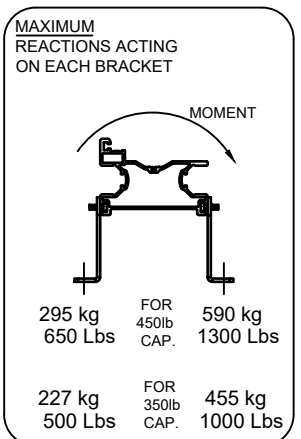

(25°~55°) (RAIL ANGLE)	D (SEAT TO FOOTREST)	E (SEAT HEIGHT)	F (FOOTREST HEIGHT)
25°	17 7/16"	22 3/4"	5 1/4"
30°	17 3/4"	22 13/16"	5 1/16"
35°	18"	22 13/16"	4 3/4"
40°	18 5/16"	22 11/16"	4 3/8"
45°	18 3/4"	22 7/16"	4"
50°	18 5/8"	22 7/16"	3 3/4"
55°	18 11/16"	21 11/16"	3"

NOTE: The range of rail angle for the commercial lift is from 25° to 45°.

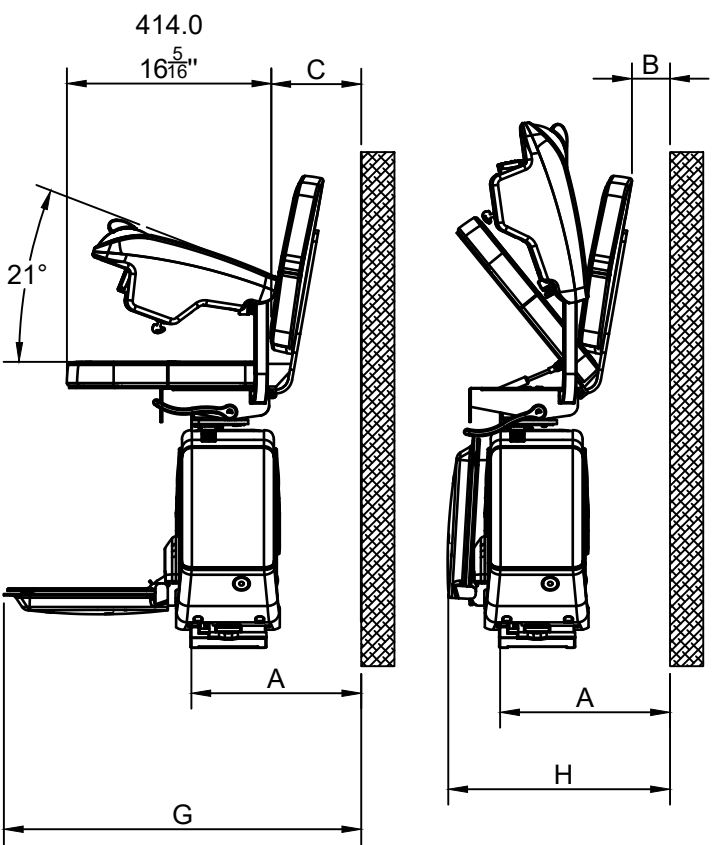

	A (RAIL FRONT TO WALL)	B (SEAT BACK TO THE WALL)	C (WALL TO FRONT OF BACK REST)	G (WALL TO THE FRONT OF UNFOLD FOOTREST)	H (WALL TO FRONT OF FOLD FOOTREST)
SEAT AT SMALL WIDTH	12 11/16"	2 3/8"	6 7/16"	27 5/8"	16 5/8"
SEAT AT NORMAL WIDTH	13 3/16"	2 1/16"	7 3/8"	28 7/16"	17 3/8"
SEAT AT BIG WIDTH	14 3/4"	3 3/4"	8"	29 1/4"	18 7/16"

RH SHOWN

CUSTOMER: _____ DATE: _____

PROJECT: _____ REVISION DATE: _____

ADDRESS: _____ COMPLETED BY: TEJINDER

Part No. **K2 PLUS**

Variant No. **N/A**

savaria

JOB No. _____ SHEET No. **1 OF 1**