

# Plus-Seat RH

REVISIONS			
REV	ECD NO.	DATE	REVISED BY

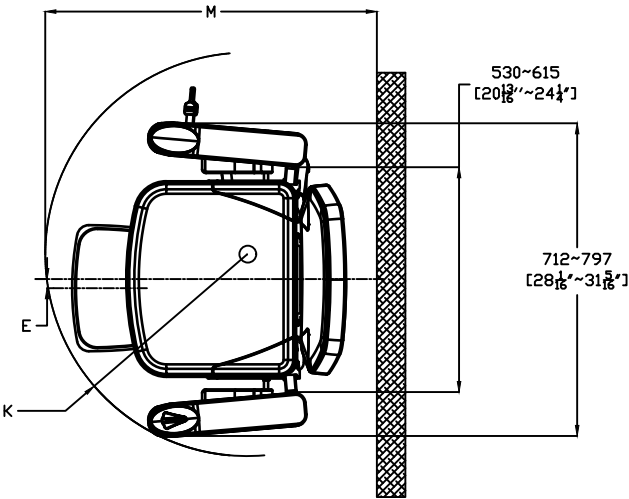
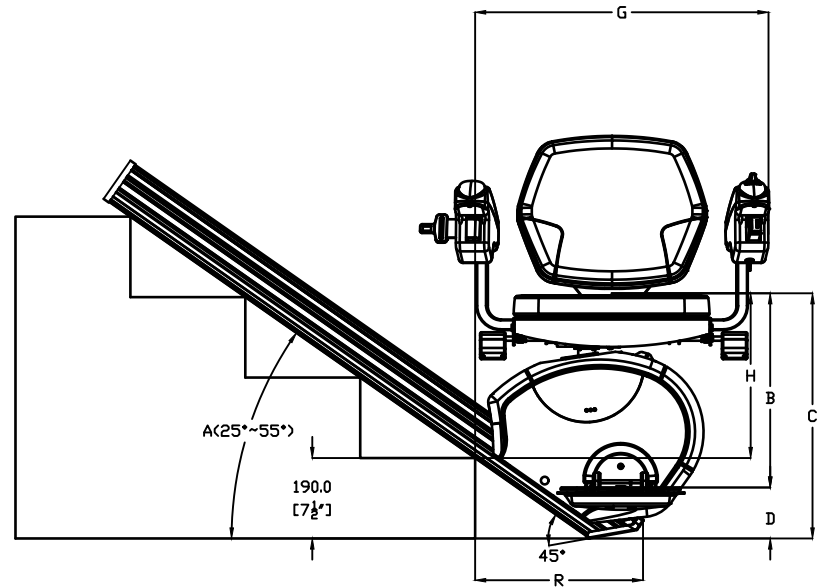
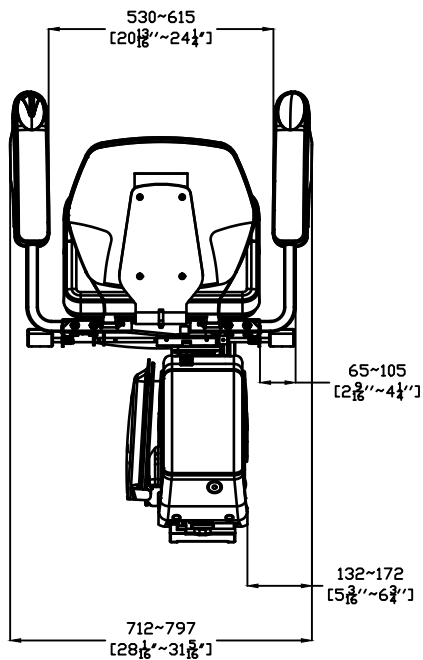
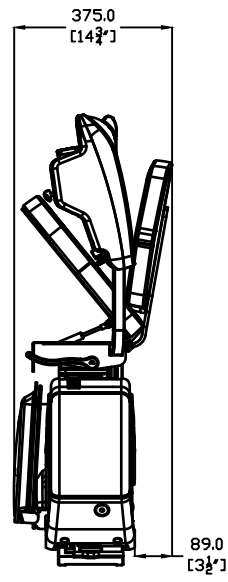
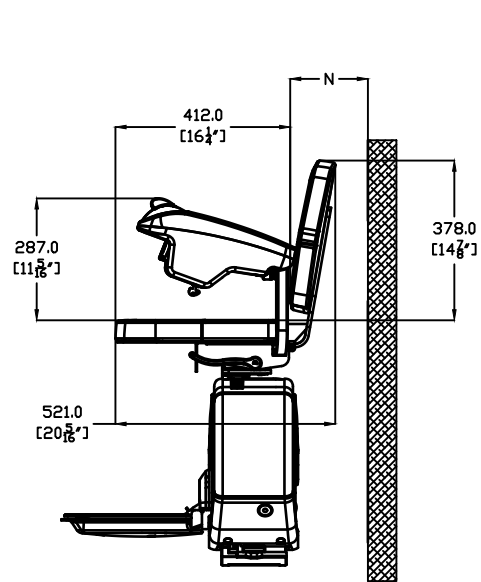

A(25°~55°)	B	C	D	E	G(S)	G(N)	G(B)	H	R
25°	17 3/8" (433mm)	22 3/8" (577mm)	5 1/8" (134mm)	2 1/8" (56mm)	29 7/8" (748mm)	30 1/4" (768mm)	31" (789mm)	15 1/2" (387mm)	20 3/8" (529mm)
30°	17 3/8" (451mm)	22 3/8" (580mm)	5 1/8" (129mm)	1 5/8" (37mm)	27 7/8" (701mm)	28 3/8" (721mm)	29 3/8" (741mm)	15 3/8" (389mm)	17 3/8" (455mm)
35°	18" (458mm)	22 3/8" (579mm)	4 3/8" (121mm)	1 3/8" (20mm)	26 3/8" (674mm)	27 3/8" (694mm)	28 3/8" (714mm)	15 3/8" (389mm)	15 3/8" (401mm)
40°	18 3/8" (465mm)	22 3/8" (576mm)	4 3/8" (110mm)	1 3/8" (3mm)	26 3/8" (660mm)	26 3/8" (680mm)	27 3/8" (700mm)	15 3/8" (385mm)	14 3/8" (359mm)
45°	18 3/8" (469mm)	22 3/8" (570mm)	4" (101mm)	1 3/8" (15mm)	25 3/8" (655mm)	26 3/8" (675mm)	27 3/8" (695mm)	15" (379mm)	12 3/8" (324mm)
50°	18 3/8" (472mm)	22 3/8" (561mm)	3 3/8" (89mm)	1 3/8" (33mm)	25 3/8" (654mm)	26 3/8" (674mm)	27 3/8" (694mm)	14 3/8" (371mm)	10 3/8" (295mm)
55°	18 3/8" (474mm)	21 3/8" (550mm)	3" (76mm)	2 3/8" (52mm)	25 3/8" (657mm)	26 3/8" (677mm)	27 3/8" (697mm)	14 3/8" (360mm)	10 3/8" (268mm)

NOTE: The range of rail angle for the commercial lift is from 25° to 45°.

	(SEAT WIDTH)	(TURNING RADIUS)	(MAX DISTANCE)	(WALL TO FRONT OF BACK REST)
SEAT AT SMALL WIDTH	20 3/8" (530mm)	18 3/8" (461mm)	29 7/8" (748mm)	6 7/8" (163mm)
SEAT AT NORMAL WIDTH	21 1/8" (536mm)	18 3/8" (478mm)	30 3/8" (785 mm)	7 3/8" (183mm)
SEAT AT BIG WIDTH	24 1/4" (615mm)	19 1/2" (495mm)	32 3/8" (822mm)	8" (203mm)

THE INFORMATION DISCLOSED HEREIN IS THE EXCLUSIVE PROPERTY OF



UNLESS OTHERWISE SPECIFIED ALL DIMENSIONS ARE IN INCHES. ALL DIMENSIONS IN ( ) ARE METRIC. TOLERANCES IN: X= ±.1 (04.3) XX= ±.03 (07.6) XXX= ±.010 (025) ANGLES X °= ±2° X\*= ±1.5°

DO NOT SCALE DRAWING REMOVE ALL BURRS & SHARP CORNERS

DESIGNED BY: TEJINDER DATE: 2019-5-13 SCALE: 1:1

DRAWN BY: TEJINDER DATE: 2019-5-13 DRAFTER: TEJINDER

TITLE: PLUS-SEAT DIMENSIONAL LAYOUT

MATERIAL: N/A

FINISH: N/A

SHEET 1 OF 2

DRAWING NO:

REVISION: 000 2019-5-13

VERSION

SIZE B

REVISIONS			
REV	ECO NO.	DATE	REVISED BY

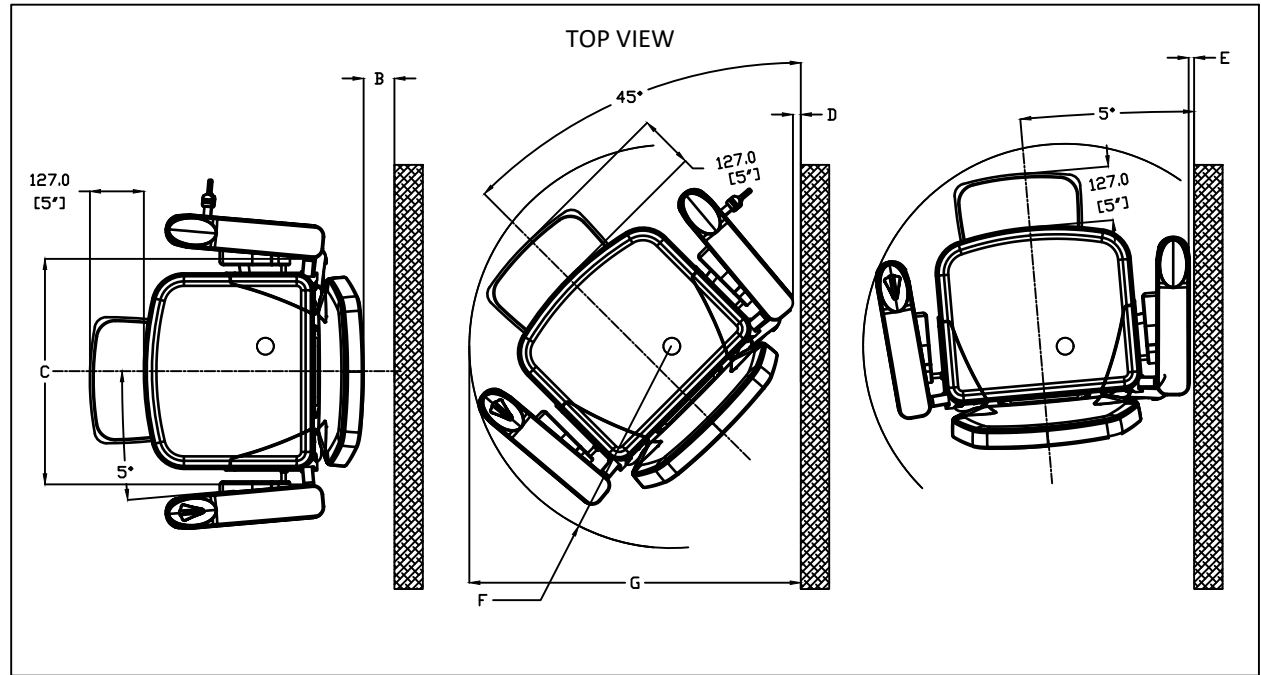
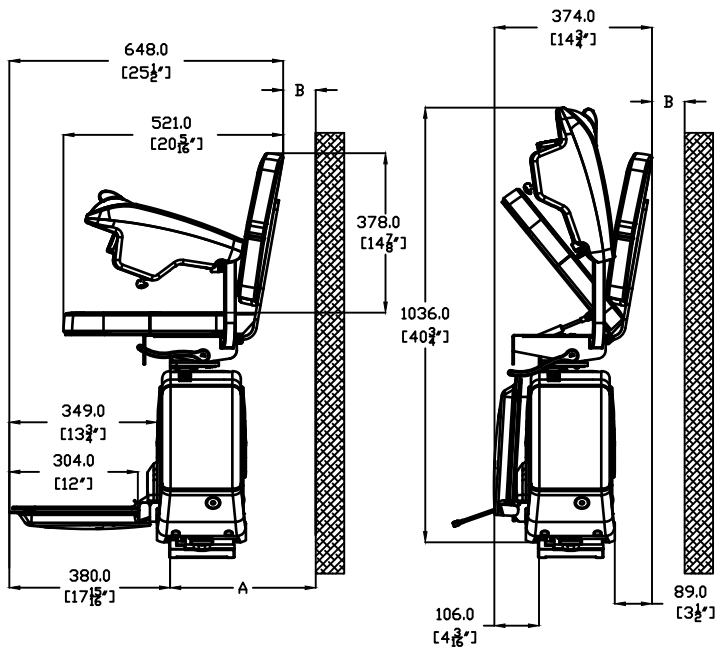

	A (RAIL FRONT TO WALL)	B (SEAT BACK TO THE WALL)	C (SEAT WIDTH)	D (ARM TO WALL AT 45°)	E (ARM TO WALL AT 85°)	F (TURNING RADIUS)	G (MAX DISTANCE)
SEAT AT NORMAL WIDTH	13 <sup>7</sup> / <sub>16</sub> \" (342mm)	2 <sup>15</sup> / <sub>16</sub> \" (75mm)	20 <sup>1</sup> / <sub>8</sub> \" (536mm)	1 <sup>11</sup> / <sub>16</sub> \" (18mm)	1 <sup>1</sup> / <sub>2</sub> \" (13mm)	18 <sup>13</sup> / <sub>16</sub> \" (478mm)	30 <sup>15</sup> / <sub>16</sub> \" (785 mm)
SEAT AT SMALL WIDTH	12 <sup>11</sup> / <sub>16</sub> \" (322mm)	2 <sup>3</sup> / <sub>16</sub> \" (55mm)	20 <sup>13</sup> / <sub>16</sub> \" (530mm)	1 <sup>1</sup> / <sub>2</sub> \" (13mm)	1 <sup>1</sup> / <sub>2</sub> \" (13mm)	18 <sup>8</sup> / <sub>16</sub> \" (461mm)	29 <sup>7</sup> / <sub>16</sub> \" (748mm)
SEAT AT BIG WIDTH	14 <sup>1</sup> / <sub>4</sub> \" (362mm)	3 <sup>3</sup> / <sub>4</sub> \" (95mm)	24 <sup>1</sup> / <sub>4</sub> \" (615mm)	7 <sup>7</sup> / <sub>8</sub> \" (23mm)	1 <sup>1</sup> / <sub>2</sub> \" (13mm)	19 <sup>1</sup> / <sub>2</sub> \" (495mm)	32 <sup>3</sup> / <sub>8</sub> \" (822mm)

THE INFORMATION DISCLOSED HEREIN IS THE EXCLUSIVE PROPERTY OF **savaria** AND MAY NOT BE USED BY OTHERS WITHOUT PRIOR WRITTEN CONSENT.

UNLESS OTHERWISE SPECIFIED ALL DIMENSIONS ARE IN INCHES. ALL DIMENSIONS IN ( ) ARE METRIC. TOLERANCES IN: (X4-3) XX = ±.03 (XX) = ±0.01 (XX) = ±0.005 (XX) = ±0.025 ANGLES X = ±0.2° Y = ±1.5°

DO NOT SCALE DRAWING	REMOVE ALL BURRS & SHARP CORNERS		REVISION: 000
DESIGNED BY: TEJINDER	DATE: 2019-5-13	SCALE: 1:1	2019-5-13
DRAWN BY: TEJINDER	DATE: 2019-5-13	DRAFTER: TEJINDER	VERSION
MATERIAL: N/A	DRAWING NO: SHEET 2 OF 2		SIZE B
FINISH: N/A			