

SECTIONAL VIEW - ORION MRL-4254 (1L)

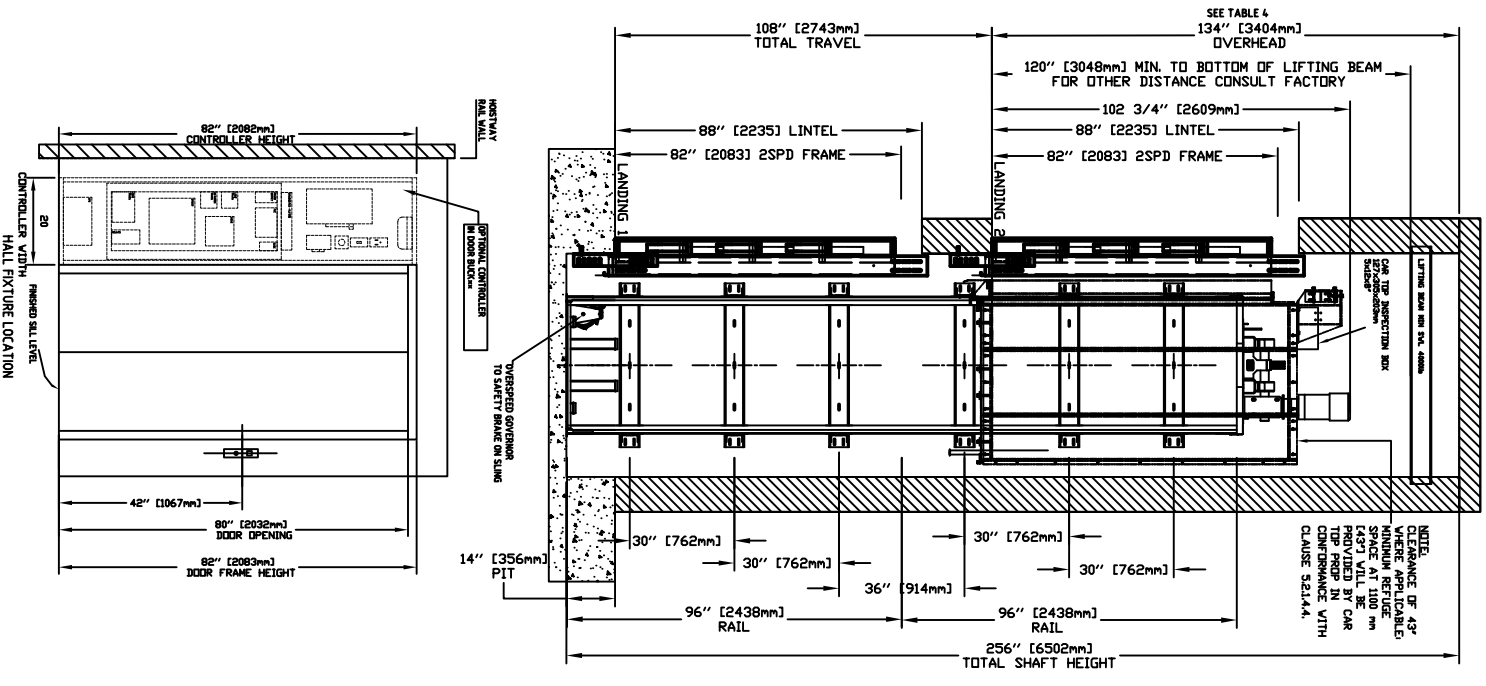

PLAN VIEW - ORION MRL-4254 (1L) 2 SPEED WITTUR DOORS

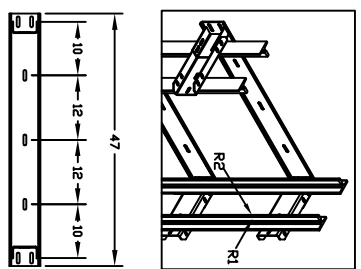
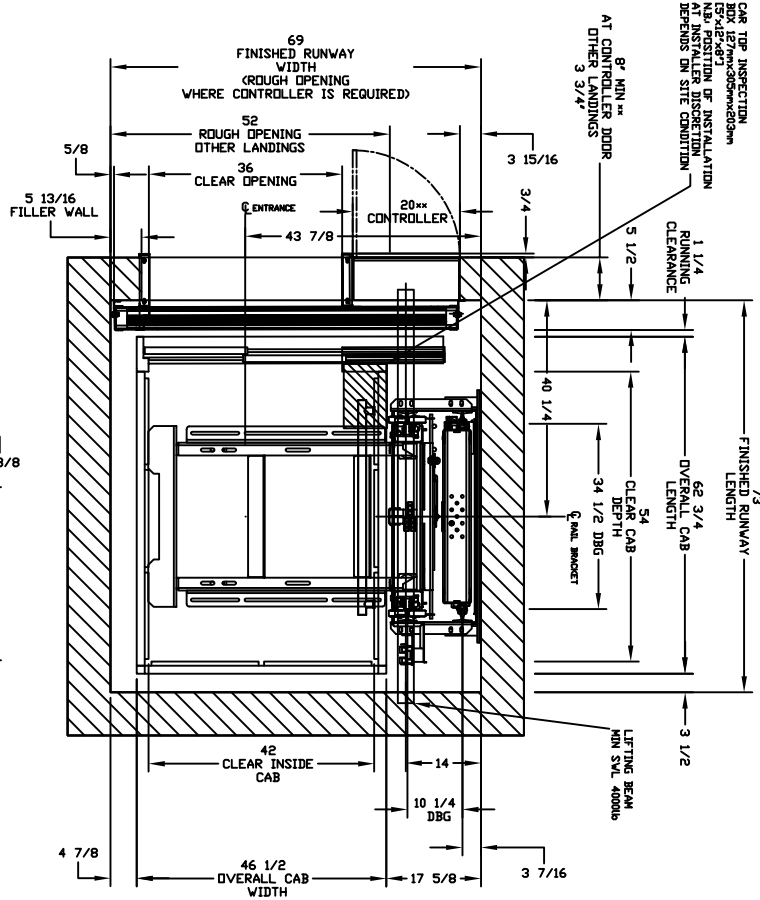

TABLE 1  
RAIL BRACKETS

RAIL FORCES	
X R1	X R2
932 lbf	260 lbf
RAIL WEIGHT:	8.8 lbm / ft

FOR TOTAL RAIL-DUTY FORCE ON RAIL BRACKET, 96 X 4.48 = 429.12 LBS. THIS FORCE MUST BE REDUCED TO 10% OF THE LOAD. SEE PIT CHARGE/ADJUST SKETCH

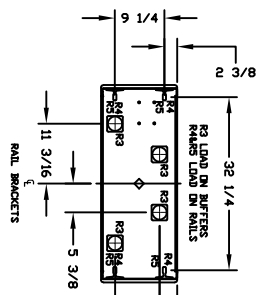

TABLE 2  
LOADS ON PIT

PIT RE-ACTION FORCE	RAIL BRACKETS
R3	3000 LBS
R4	8000 LBS
R5	5900 LBS

NOTE: ALL INFORMATION IS SUBJECT TO CHANGE. PLEASE REFER TO OUR ONLINE DRAWINGS AT WWW.SAVARIA.COM FOR THE MOST RECENT UPDATES.

NOTE: ALL INFORMATION IS SUBJECT TO CHANGE. PLEASE REFER TO OUR ONLINE DRAWINGS AT WWW.SAVARIA.COM FOR THE MOST RECENT UPDATES.

NOTE: ALL INFORMATION IS SUBJECT TO CHANGE. PLEASE REFER TO OUR ONLINE DRAWINGS AT WWW.SAVARIA.COM FOR THE MOST RECENT UPDATES.

NOTE: ALL INFORMATION IS SUBJECT TO CHANGE. PLEASE REFER TO OUR ONLINE DRAWINGS AT WWW.SAVARIA.COM FOR THE MOST RECENT UPDATES.

PROVISIONS BY OTHERS

GENERAL - THE USER MUST BE IN ACCORDANCE WITH LOCAL, STATE AND FEDERAL CODES AND REGULATIONS. THE USER MUST BE RESPONSIBLE FOR OBTAINING ALL NECESSARY PERMITS AND APPROVALS. THE USER MUST BE RESPONSIBLE FOR OBTAINING ALL NECESSARY PERMITS AND APPROVALS. THE USER MUST BE RESPONSIBLE FOR OBTAINING ALL NECESSARY PERMITS AND APPROVALS.

TABLE 3

WATTAGE & EQUIP. (VA)	PHASE	FLA
30 AMPS	208 VAC	26.9 AMPS
60 AMPS	208 VAC	53.8 AMPS
15 AMPS	115 V	

NOTE: THE USER MUST BE RESPONSIBLE FOR OBTAINING ALL NECESSARY PERMITS AND APPROVALS. THE USER MUST BE RESPONSIBLE FOR OBTAINING ALL NECESSARY PERMITS AND APPROVALS. THE USER MUST BE RESPONSIBLE FOR OBTAINING ALL NECESSARY PERMITS AND APPROVALS.

TABLE 4  
PIT / OVERHEAD REQUIREMENTS

MAX. SPEED (ft/min)	PIT	TOTAL TRAVEL	MIN OVERHEAD EXISTING BLDG	MIN OVERHEAD EXISTING BLDG
30	14"	34"(7044)	10"(254)	10"(254)

NOTE: ADDITIONAL PIT REQUIREMENTS MAY BE REQUIRED FOR SPEEDS GREATER THAN 30 FT/MIN. PLEASE CONTACT SAVARIA FOR MORE INFORMATION.