

SECTIONAL VIEW - ORION-4260 (1R)

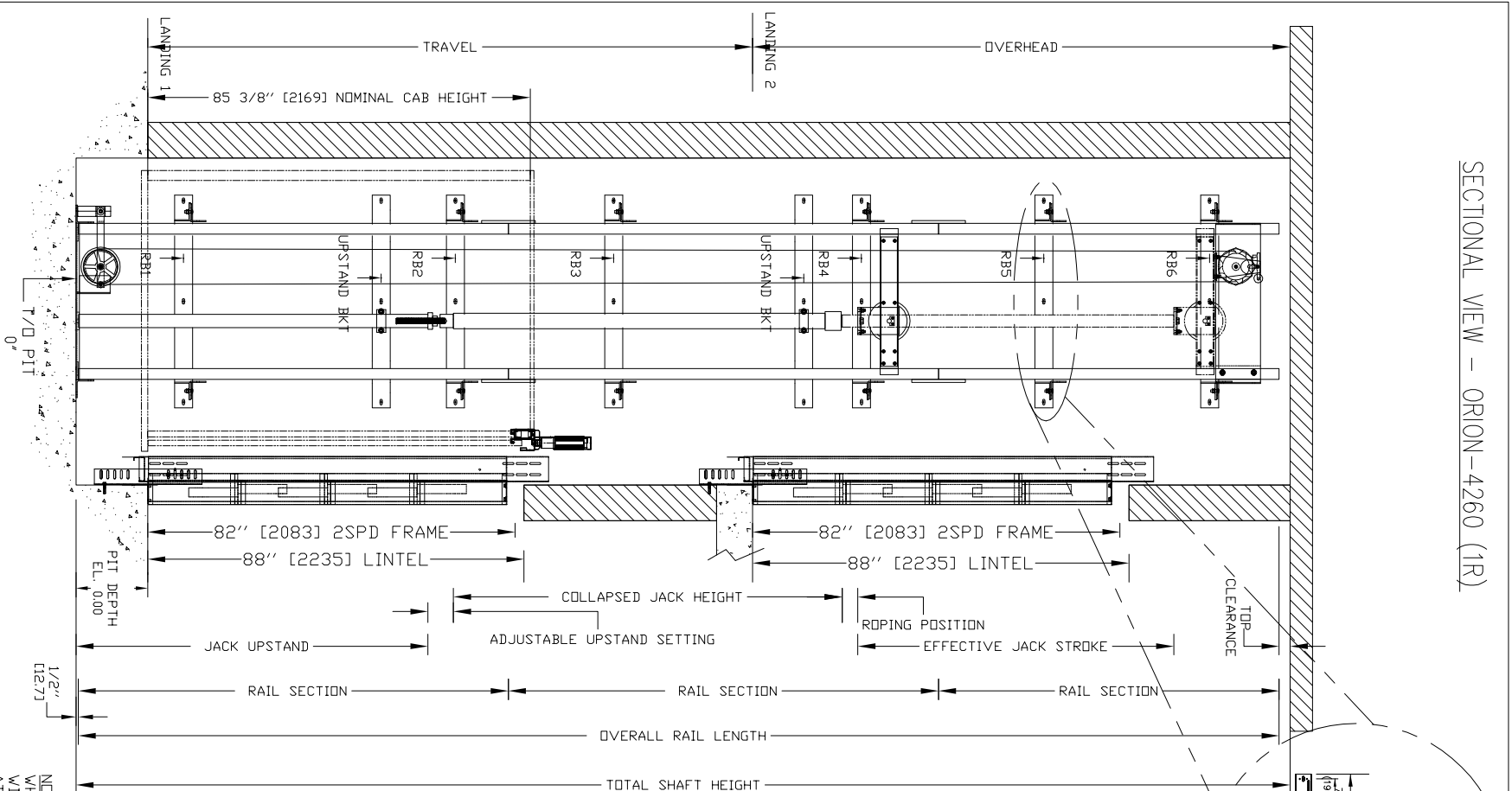

PIT / OVERHEAD REQUIREMENTS

MAX. SPEED (ft./min)	PIT	TOTAL OVERHEAD TRAVEL	NEW BLDG. EXISTING BLDG
30	14" ***	134" (3404)	108" (2743)

*** NOTE: Additional pit equipment required when over 36" deep, consult your local dealer for details

PLAN VIEW - ORION17-4260 (1R) 2 SPEED WITUR DOORS

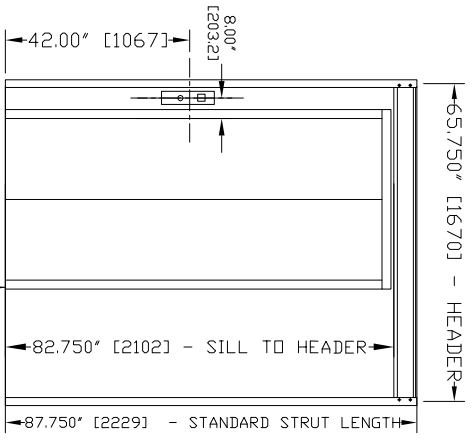
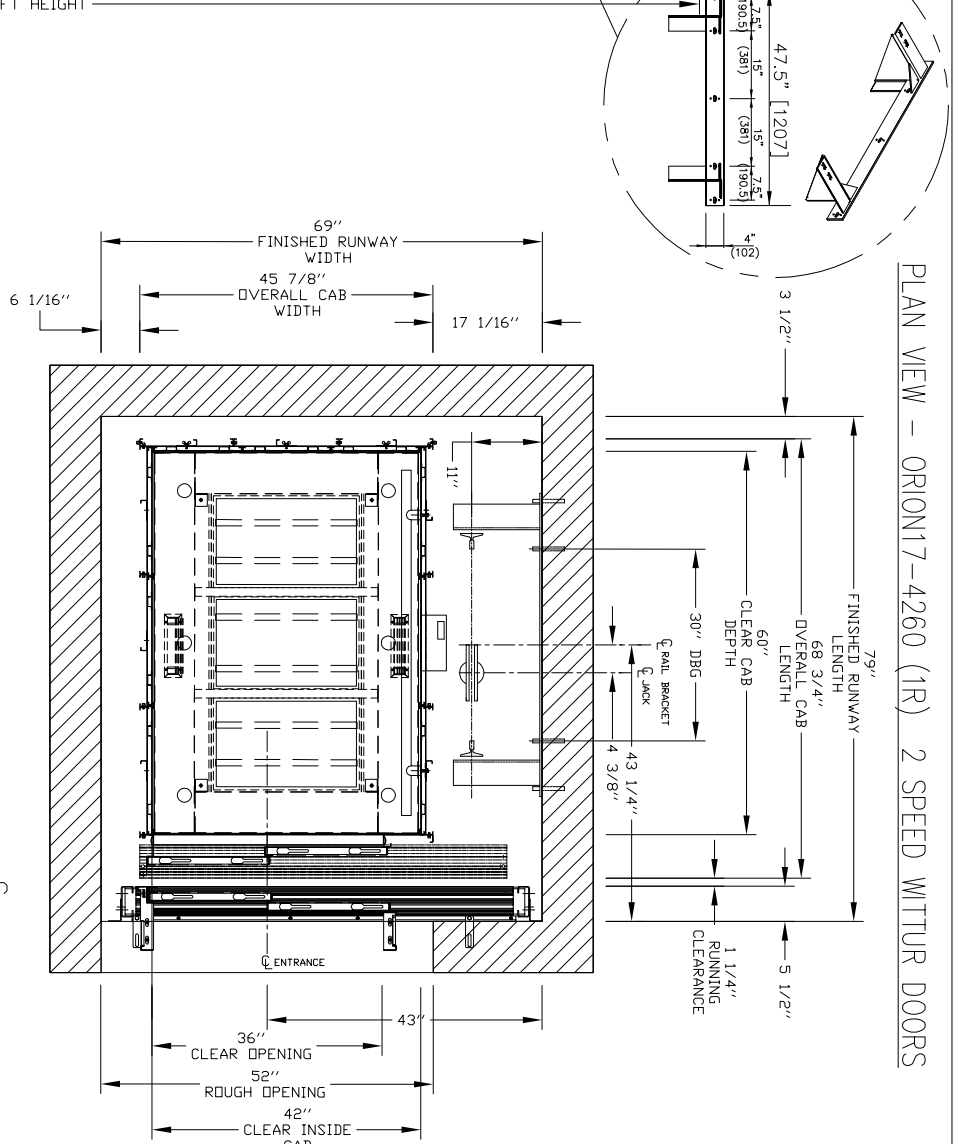

NOTE A
WHERE SMOKE DETECTORS ARE REQUIRED, WIRING FROM A NORMALLY CLOSED CONTACT AT BOTH THE DESIGNATED RETURN LANDING, SMOKE DETECTORS AND ALTERNATE RETURN LANDING SMOKE DETECTOR SHALL BE PROVIDED TO THE CONTROLLER. A NORMALLY CLOSED CONTACT REPRESENTING ALL OTHER SMOKE DETECTORS MUST BE PROVIDED TO THE CONTROLLER.

NOTE B
ALL INFORMATION IS SUBJECT TO CHANGE. PLEASE REFERENCE OUR ON-LINE DRAWINGS AT WWW.CONCORDELEVATOR.COM FOR THE MOST RECENT UPDATES

PROVISIONS BY OTHERS

***GENERAL**
HOISTWAY - THE HOISTWAY MUST BE IN ACCORDANCE WITH SAFETY CODE FOR ELEVATORS (ASME A17.1 OR B44-2000) AND ALL STATE/PROVINCIAL AND LOCAL CODES.
PLUMB HOISTWAY - DUE TO CLOSE RUNNING CLEARANCES OWNER/AGENT MUST ENSURE THAT HOISTWAY AND PIT (WHERE PROVIDED) ARE LEVEL, PLUMB AND SQUARE AND ARE IN ACCORDANCE WITH THE DIMENSIONS ON THESE DRAWINGS.
MINIMUM OVERHEAD CLEARANCE - OWNER/AGENT MUST ENSURE MINIMUM OVERHEAD CLEARANCE IS IN COMPLIANCE WITH CODES.
CONSTRUCTION SITE - OWNER/AGENT TO PROVIDE ALL MASONRY, CARPENTRY AND DRYWALL WORK AS REQUIRED AND SHALL PATCH AND MAKE GOOD (INCLUDING FINISH PAINTING) ALL AREAS WHERE WALLS/FLOORS MAY REQUIRE TO BE CUT, DRILLED OR ALTERED IN ANY WAY TO PERMIT THE PROPER INSTALLATION OF THE LIFT.
DIMENSIONS
CONTRACTOR/CUSTOMER TO VERIFY ALL DIMENSIONS AND REPORT ANY DISCREPANCIES TO OUR OFFICE IMMEDIATELY.

***STRUCTURAL**
FLOOR/SUPPORT WALL LOADS - STRUCTURAL ENGINEER TO ASSURE THAT BUILDING AND SHAFT WILL SAFELY SUPPORT ALL LOADS IMPOSED BY THE LIFT EQUIPMENT. REFER TO THE TABLES ON THIS DRAWING FOR LOADS IMPOSED BY THE EQUIPMENT.
DOORS - SUITABLE LINTELS MUST BE PROVIDED BY OWNER/AGENT. DOOR FRAMES ARE NOT DESIGNED TO SUPPORT OVERHEAD WALL LOADS.
***MACHINE ROOM**
LOCATION / ACCESS - MACHINE ROOM LOCATED AT THE LOWEST LEVEL ADJACENT TO HOISTWAY, UNLESS SHOWN OTHERWISE ON THE LAYOUT DRAWINGS. FIELD ADJUSTMENT BY INSTALLER MAY BE NECESSARY TO MEET JOB SITE CONDITIONS OR REGULATIONS. ACCESS TO MACHINE ROOM TO BE THROUGH A SELF CLOSING AND SELF LOCKING DOOR.
SLEEVES FOR OIL & ELECTRIC LINES - PROVIDED BY OTHERS, FROM MACHINE ROOM TO HOISTWAY. (POSITION PER INSTALLERS INSTRUCTIONS).

INPUT VOLTAGE (V/PH/CYCLE)	DISCONNECT SIZE (AMPS)	TIME DELAY (SECS)	FUSE (AMPS)	FULL LOAD CURRENT (AMPS)
MOTOR INFO	208/3PH/60HTZ	30	30	15.6
	230/1PH/60HTZ	60	40	21
CAB LIGHTS	115/1PH	15	15	

***ELECTRICAL**
POWER SUPPLY - (SEE SPECIFICATIONS) LOCKABLE FUSED DISCONNECT WITH AUXILIARY CONTACT TO BRAKE THE BATTERY FEED, OR CIRCUIT BREAKERS WITH A 3-POLE BREAKER FOR BATTERY FEED REQUIRED. (IN COMPLIANCE WITH ELECTRICAL CODE, AS FOLLOWS: (LOCATED ON WALL ON LOCK JAMB SIDE OF MACHINE ROOM DOOR)
PERMANENT POWER - BEFORE INSTALLATION CAN BEGIN, PERMANENT POWER MUST BE SUPPLIED.
LIGHTING - OWNER/AGENT TO ENSURE AT LEAST 5 FTC OR 54 LUX AMBIENT LIGHTING OVER ELEVATOR AREA.

***ENTRANCES**
FASCIA PANEL BELOW UPPER LEVEL ENTRANCE - WHERE REQUIRED, FASCIA PANEL MUST BE FASTENED TO A SOLID WALL AND BE PERPENDICULAR TO THE FLOOR AND WALLS. HOISTWAY FASCIA IS NOT SELF-SUPPORTING FOR LONG, CONTINUOUS RUNS VOID OF ENTRANCES. ADEQUATE SUPPORT AND THE FASCIA MUST BE PROVIDED BY OTHERS.
ENTRANCE ASSEMBLIES - ENTRANCE ASSEMBLIES MUST BE ADJUSTED TO ALIGN WITH PLATFORM AND INTERLOCK EQUIPMENT. OTHERS TO ALLOW AN ADEQUATE ROUGH OPENING.
RETURN WALLS - RETURN WALLS AT ENTRANCES MUST BE BUILT-IN BY OTHERS AFTER ENTRANCE ASSEMBLIES ARE IN PLACE. ENTRANCE ASSEMBLY MUST BE SECURELY FASTENED TO WALLS BY ELEVATOR CONTRACTOR.

SEISMIC ZONES 0 AND 1

CAB WIDTH	DIST (CD)	PIT PRE-ACTION FORCE
42"	31625"	R3 8000 LBS
48"	31625"	R4 3000 LBS
54"	31625"	R5 9000 LBS

RAIL FORCES

RAIL WEIGHT	8.0 lbs/ft
*R1	260 lbf
*R2	260 lbf

FOR LOCAL APPLICATION OF PIT LOAD, SEE PIT CHANNEL/BUFFER SKETCH.

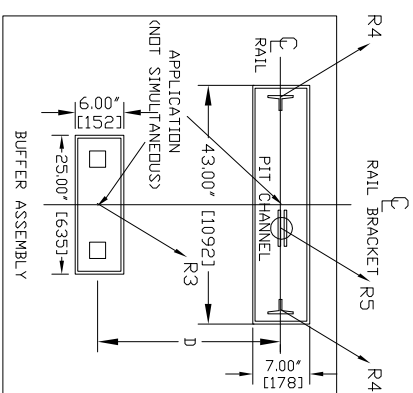

ORION17 MODEL 4260 (1R)

REV-000