

SPECIFICATIONS

SUPPORT LOAD DIAGRAM

SELF SUPPORT POST:

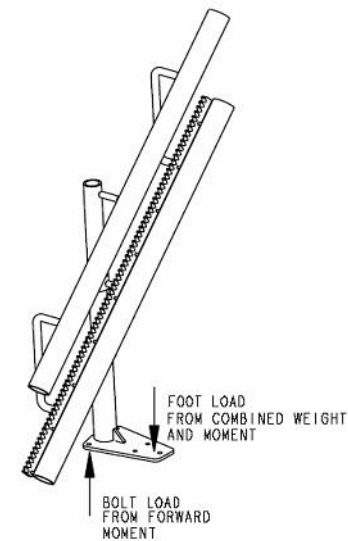

DESIGN FOOT LOADS ARE:
 4684N (1053 LBF) VERTICAL FOOT LOAD
 2344N (527LBF) BOLT TENSILE LOAD
 AT BACK TWO FASTENER LOCATIONS
 DUE TO FORWARD MOMENT
 -USE THE SAME FASTENERS IN 3 LOCATIONS

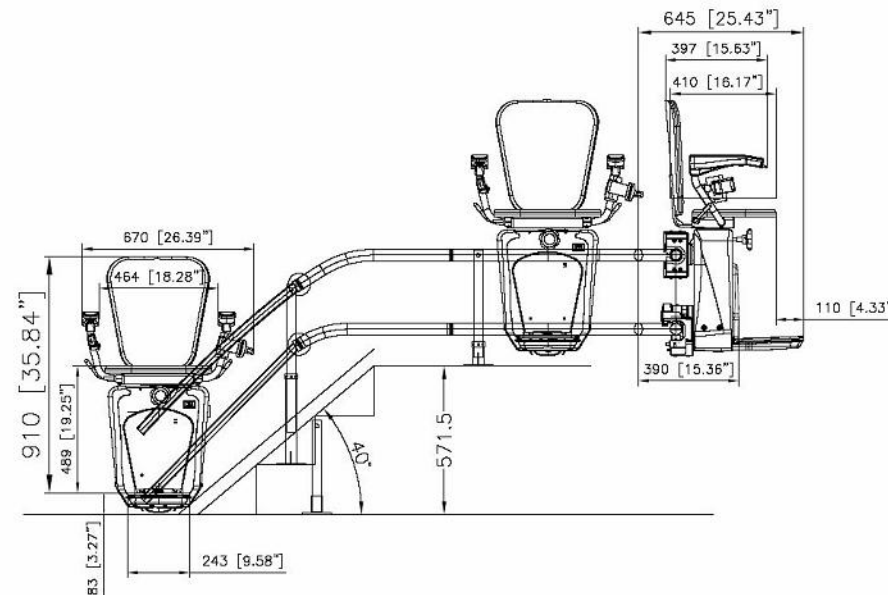

GENERAL

CLASSIFICATION:	UNENCLOSED CHAIR LIFT
CODE:	RESIDENTIAL & COMMERCIAL
MODEL:	STAIRFRIEND
CAPACITY:	350 lbs [160 kg] ONE PERSON IN CHAIRLIFT
SPEED:	25 ft/min [7.2 m/min]
CHAIR SIZE:	16.625"x14.75" [422x375]
POWER SUPPLY:	120V, 15A, 60Hz, SINGLE PHASE

MOTOR:	24 V (DC), 0.5 Hp
DRIVE SYSTEM:	RACK AND PINION

SELF SUPPORT STAIR POST:	YES
INTERMEDIATE STOPS:	YES/NO
90 DEGREE BEND:	0
180 DEGREE BEND:	1
CUSTOM BEND:	NO
DROP NOSE:	NO OR YES
SEAT CHAIR MODEL	L OR V

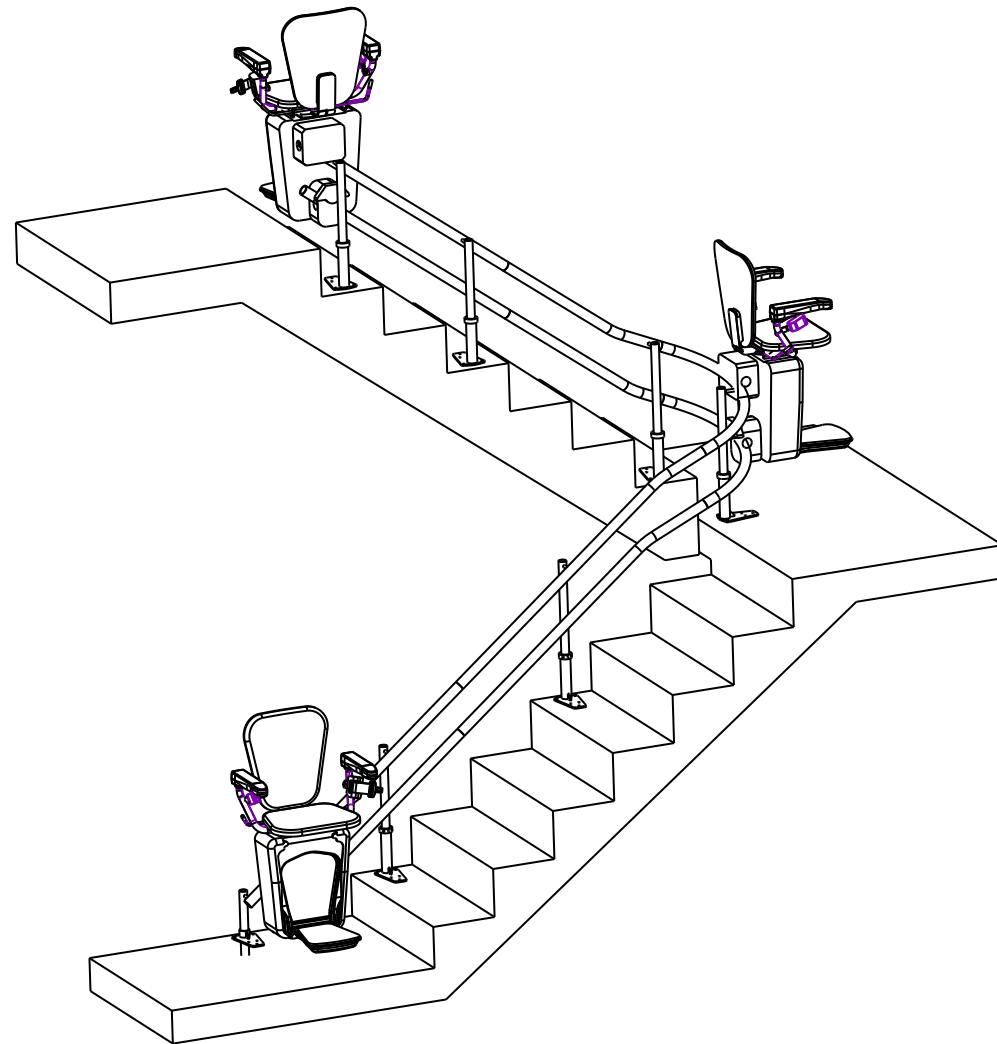

DIMENSIONS ARE
IN INCHES

APPROVAL DWG

CUSTOMER:	DATE: ??	Part No.	STAIRFRIEND
PROJECT: 180 STAIR INSIDE RAIL LH	REVISION DATE: ??	Variant No.	
ADDRESS:	COMPLETED BY:	© savaria	
		JOB No.	SHEET No. 1 OF 3

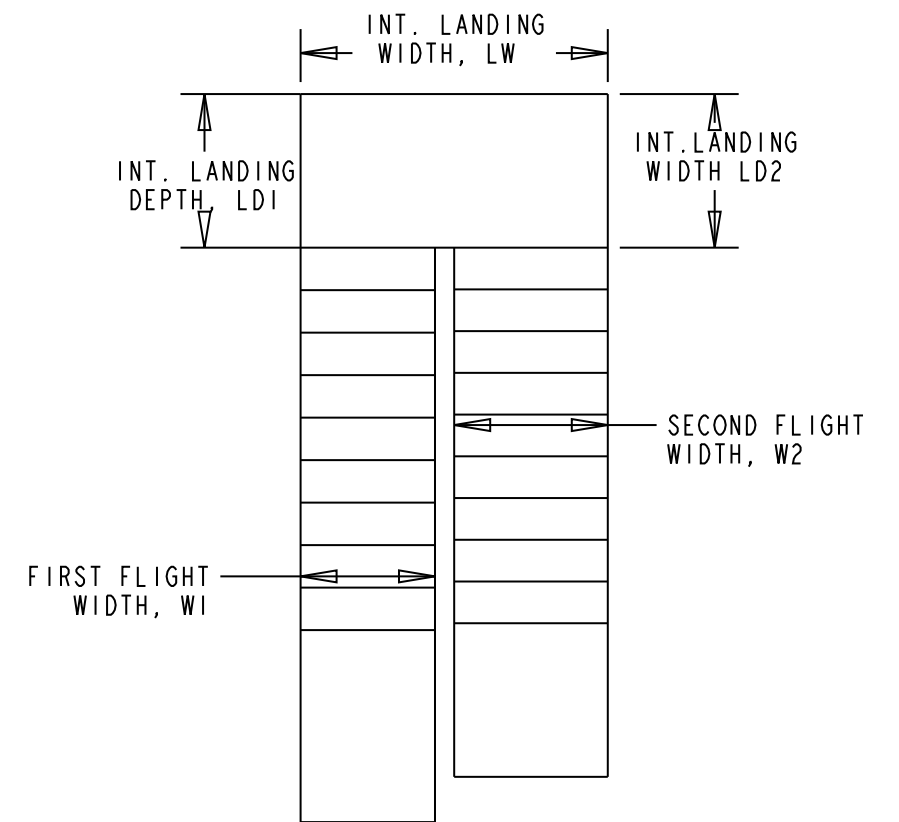
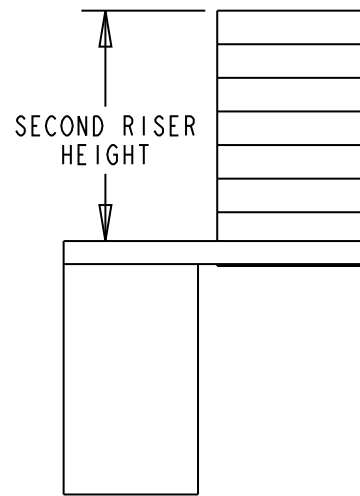
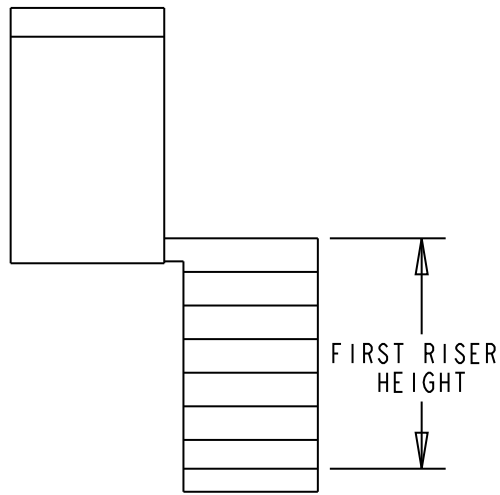
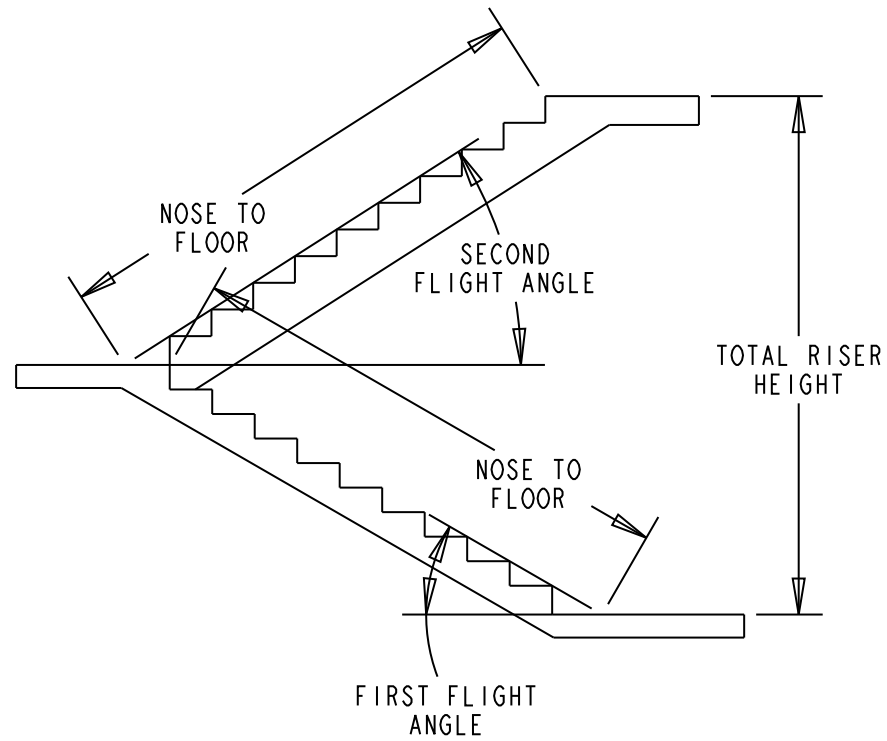
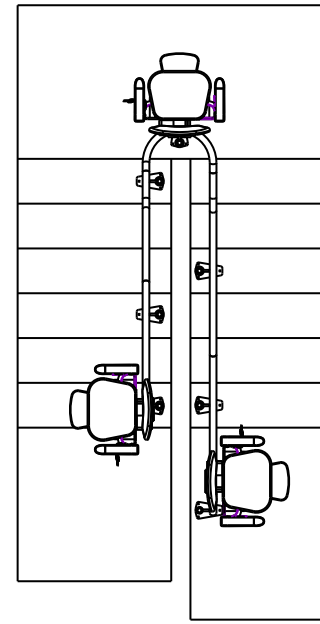
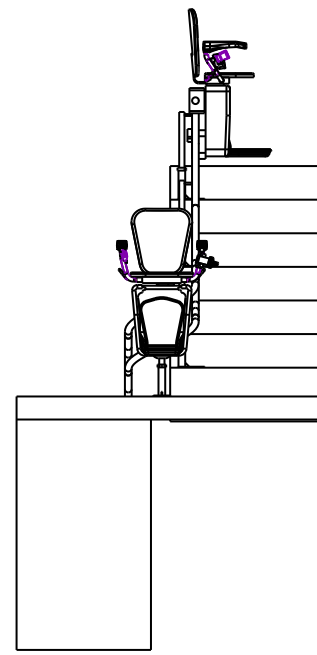
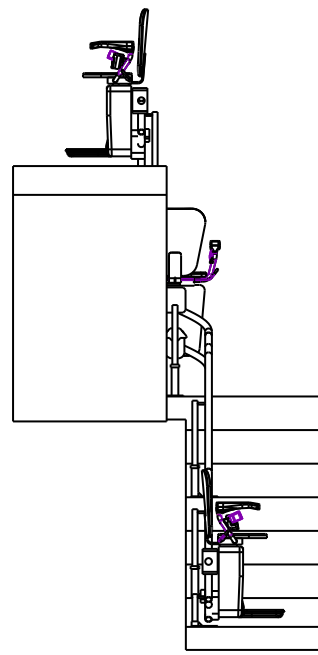
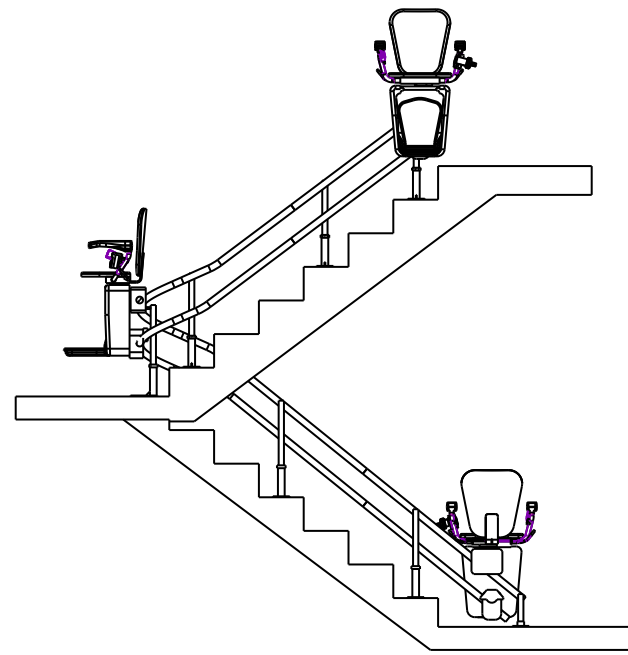

DIMENSIONS ARE IN INCHES

APPROVAL DWG

CUSTOMER:	DATE:
PROJECT: 180 STAIR INSIDE RAIL LH	REVISION DATE:
ADDRESS:	COMPLETED BY:

Part No. STAIRFRIEND	
Variant No.	
© savaria 	
JOB No.	SHEET No. 2 OF 3

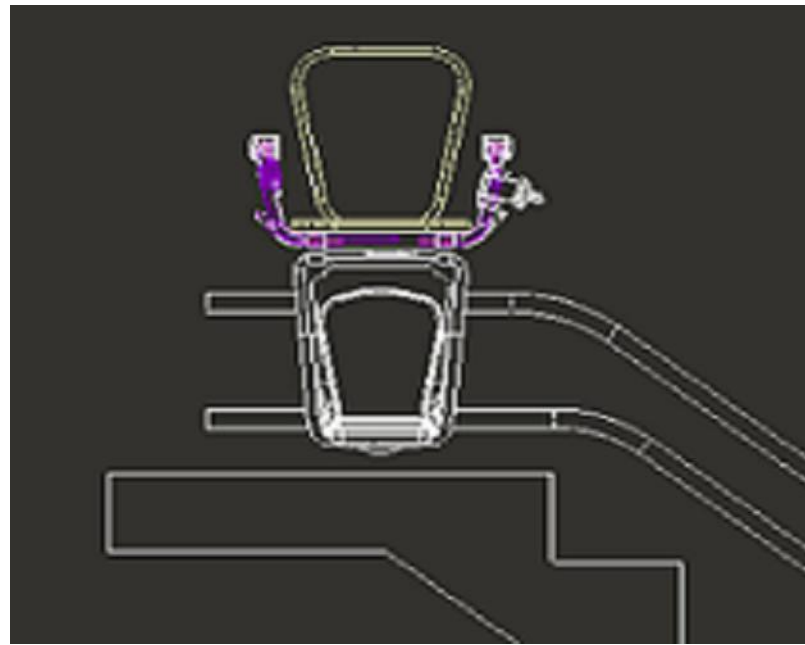

OVERRUN AT TOP

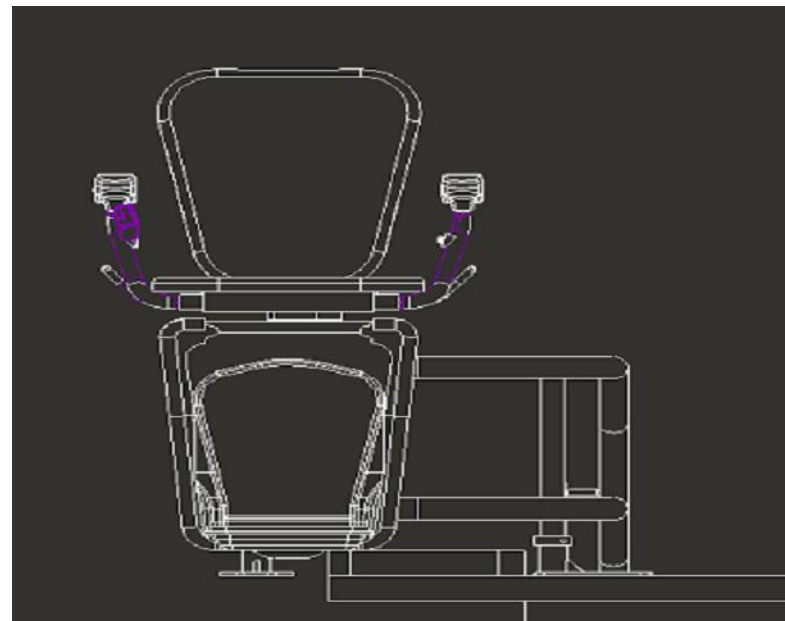

90 DEG PARKING AT TOP

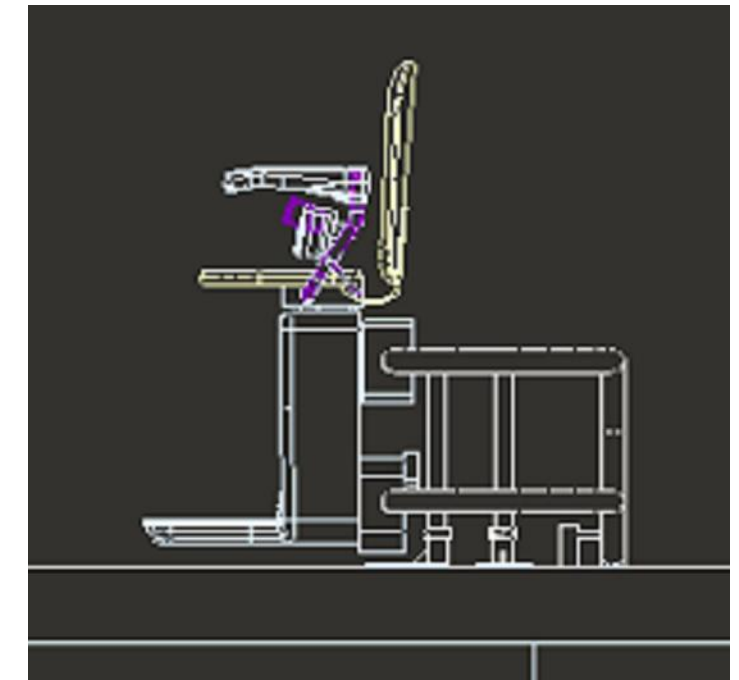

180 DEG PARKING AT TOP



OVERRUN AT BOTTOM

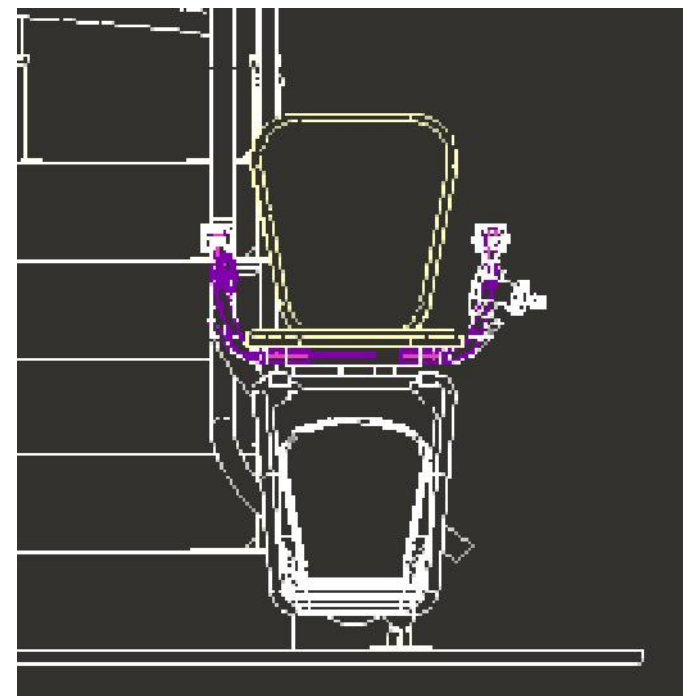

90 DEG PARKING AT BOTTOM

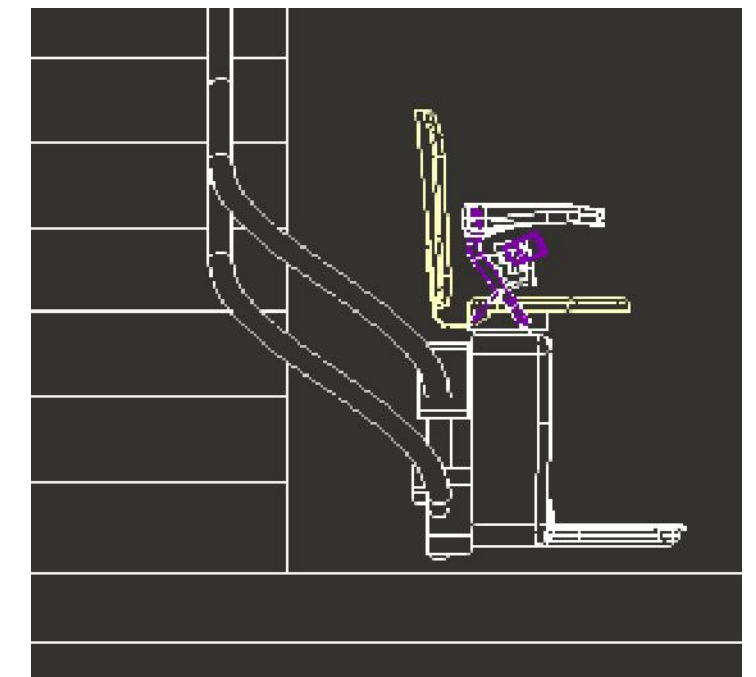

180 DEG PARKING AT BOTTOM

DIMENSIONS ARE
IN INCHES

APPROVAL DWG

CUSTOMER:		DATE:	Part No.
PROJECT: 180 STAIR INSIDE RAIL LH		??	STAIRFRIEND
ADDRESS:		REVISION DATE:	Variant No.
		??	
		COMPLETED BY:	© savaria 
			JOB No.
			SHEET No. 3 OF 3