

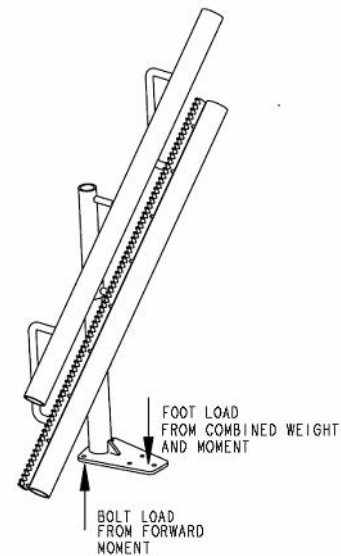

SUPPORT LOAD DIAGRAM

SELF SUPPORT POST:

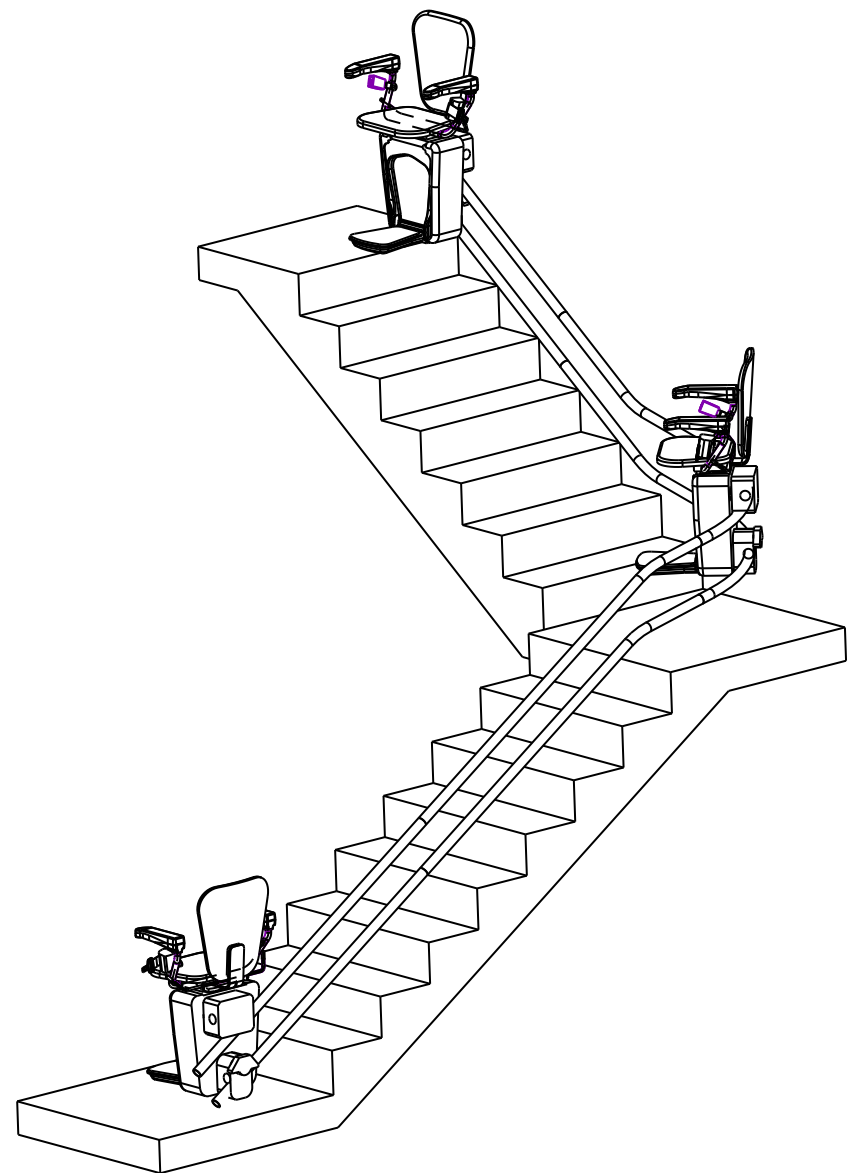

DESIGN FOOT LOADS ARE:  
4684N (1053 LBF) VERTICAL FOOT LOAD  
2344N (527LBF) BOLT TENSILE LOAD  
AT BACK TWO FASTENER LOCATIONS  
DUE TO FORWARD MOMENT  
-USE THE SAME FASTENERS IN 3 LOCATIONS

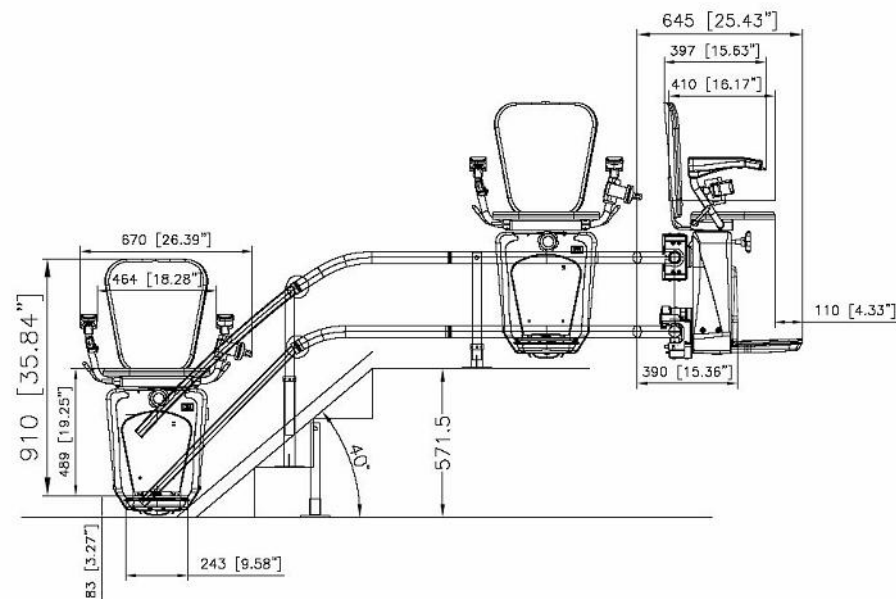

# SPECIFICATIONS

## GENERAL

CLASSIFICATION:	UNENCLOSED CHAIR LIFT
APPLIED CODE:	CODE: RESIDENTIAL OR COMMERCIAL
MODEL:	STAIRFRIEND
CAPACITY:	350 lbs [160 kg] ONE PERSON IN CHAIRLIFT
SPEED:	25 ft/min [7.2 m/min]
CHAIR SIZE:	16.625"x14.75" [422x375]
POWER SUPPLY:	120V, 15A, 60Hz, SINGLE PHASE

MOTOR:	24 V (DC), 0.5 Hp
DRIVE SYSTEM:	RACK AND PINION

SELF SUPPORT STAIR POST:	YES
INTERMEDIATE STOPS:	YES/NO
90 DEGREE BEND:	1
180 DEGREE BEND:	0
CUSTOM BEND:	NO
DROP NOSE:	NO OR YES
SEAT CHAIR MODEL	L OR V

DIMENSIONS ARE IN INCHES

APPROVAL DWG

CUSTOMER:	DATE:
PROJECT: 90 STAIR OUTSIDE RAIL LH	REVISION DATE:
ADDRESS:	COMPLETED BY:

Part No. <b>STAIRFRIEND</b>	
Variant No.	
© savaria	
JOB No.	SHEET No. 1 OF 3



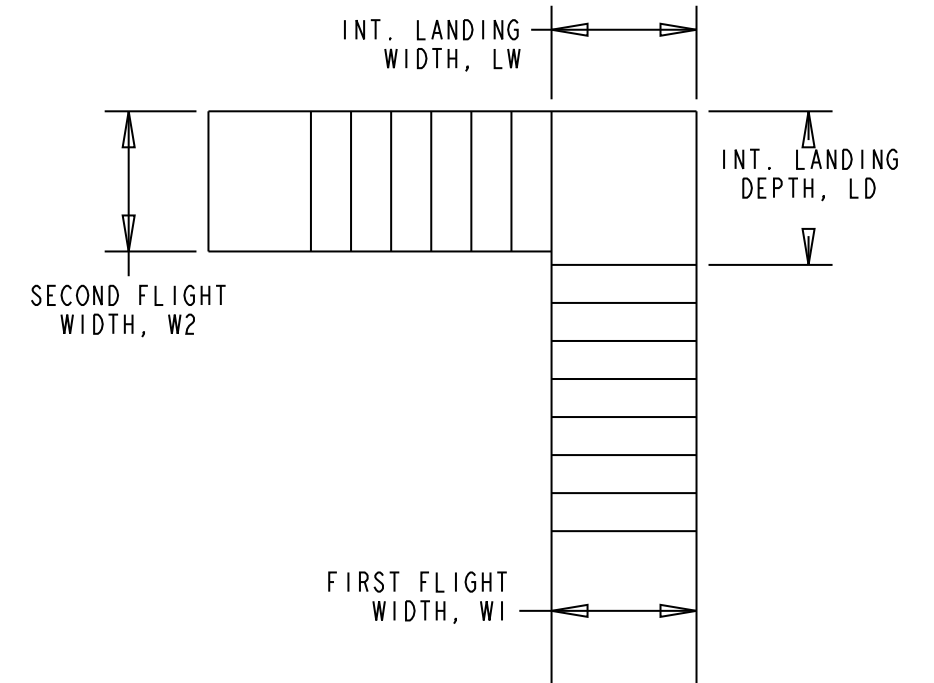
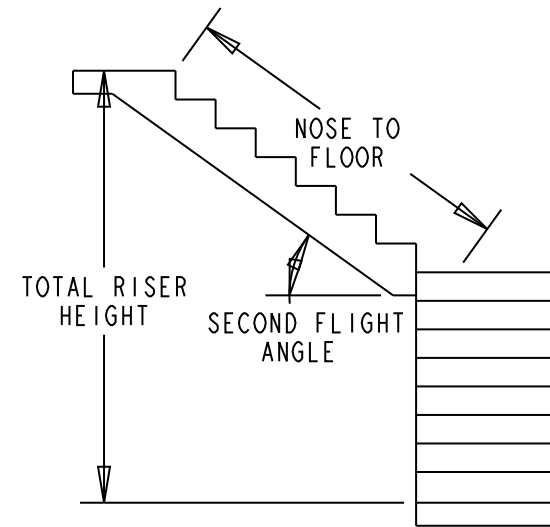
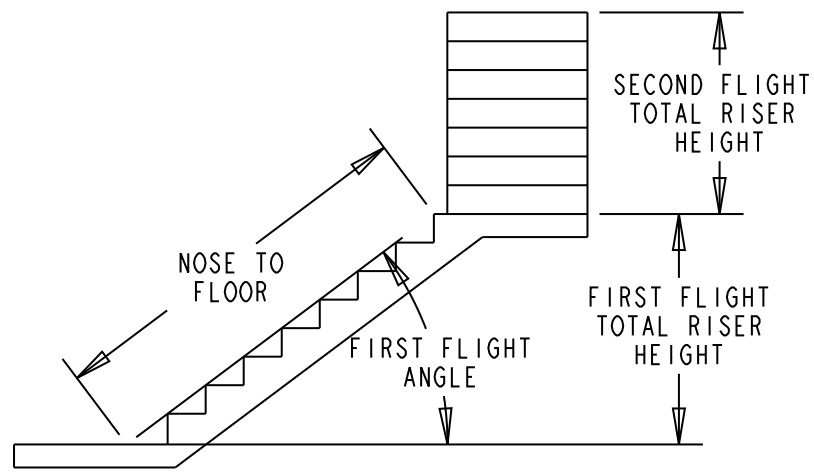
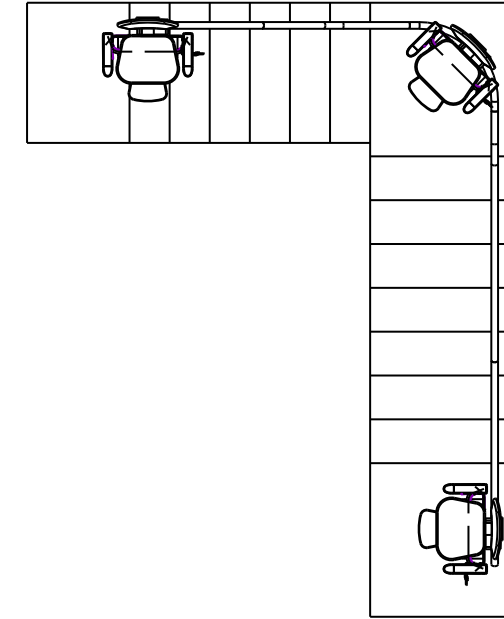
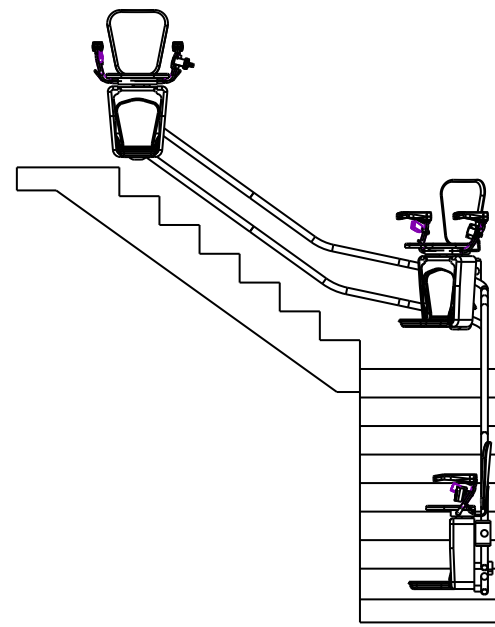
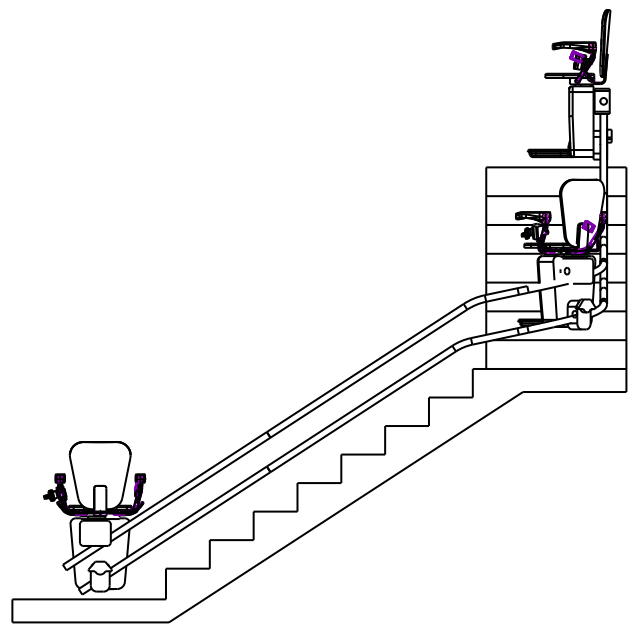

DIMENSIONS ARE  
IN INCHES

APPROVAL DWG

CUSTOMER:	DATE:
PROJECT: 90 STAIR OUTSIDE RAIL LH	REVISION DATE:
ADDRESS:	COMPLETED BY:

Part No. STAIRFRIEND	
Variant No.	
© savaria 	
JOB No.	SHEET No. 2 OF 3

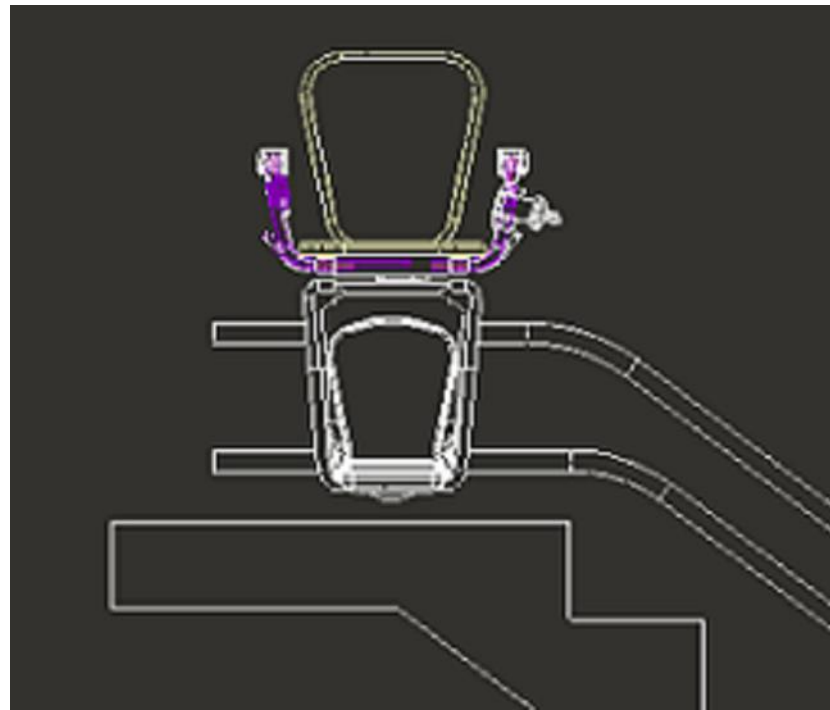

OVERRUN AT TOP



90 DEG PARKING AT TOP

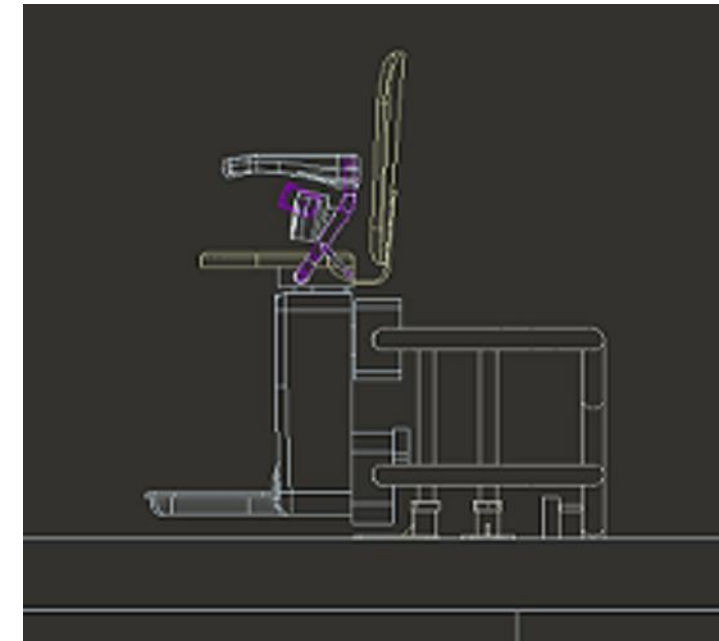

180 DEG PARKING AT TOP

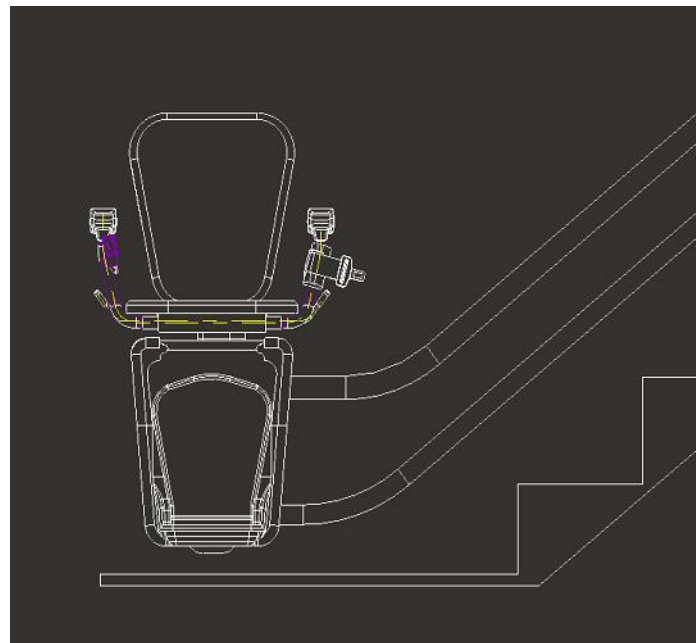

BOTTOM OVERRUN

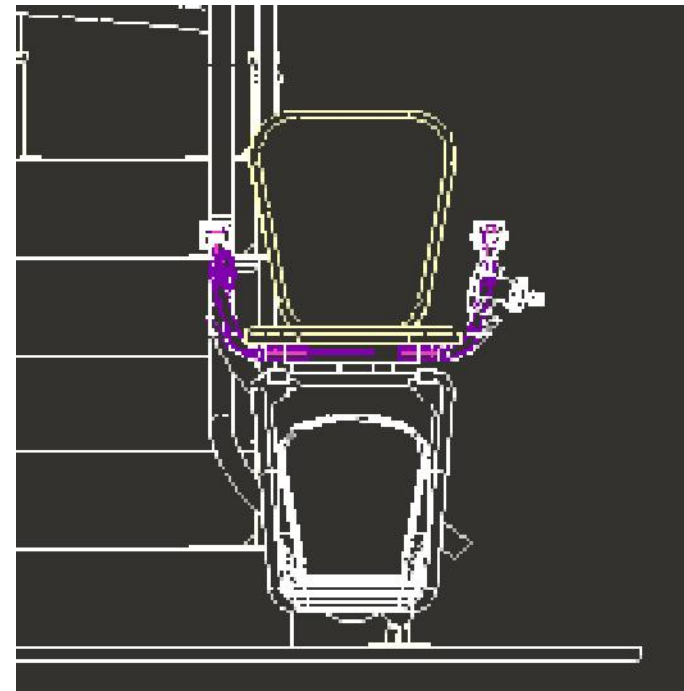

90 DEG PARKING AT BOTTOM



180 DEG PARKING AT BOTTOM

DIMENSIONS ARE IN INCHES

APPROVAL DWG

CUSTOMER:		DATE:	Part No. <b>STAIRFRIEND</b>	
PROJECT: 90 STAIR OUTSIDE RAIL LH		REVISION DATE:	Variant No.	
ADDRESS:		COMPLETED BY:	© savaria	
			JOB No.	SHEET No. 3 OF 3

